



**MVAPICH**

MPI, PGAS and Hybrid MPI+PGAS Library



High-Performance  
Big Data

# **HPC Meets Cloud: Opportunities and Challenges in Designing High-Performance MPI and Big Data Libraries on Virtualized InfiniBand Clusters**

**Keynote Talk at CloudCom (December 2016)**

by

**Dhabaleswar K. (DK) Panda**

The Ohio State University

E-mail: [panda@cse.ohio-state.edu](mailto:panda@cse.ohio-state.edu)

<http://www.cse.ohio-state.edu/~panda>

# High-End Computing (HEC): ExaFlop & ExaByte

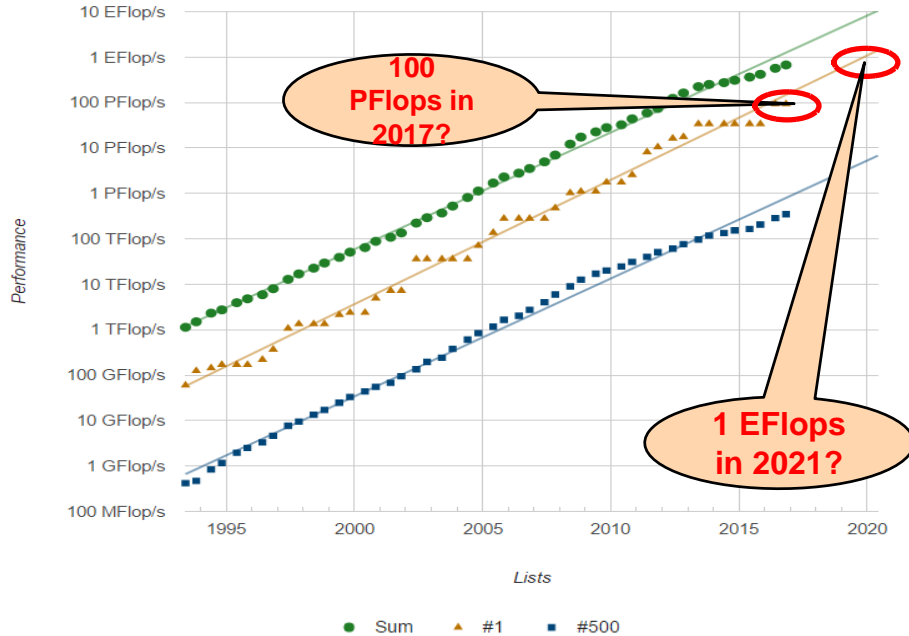

**Expected to have an ExaFlop system in 2021!**

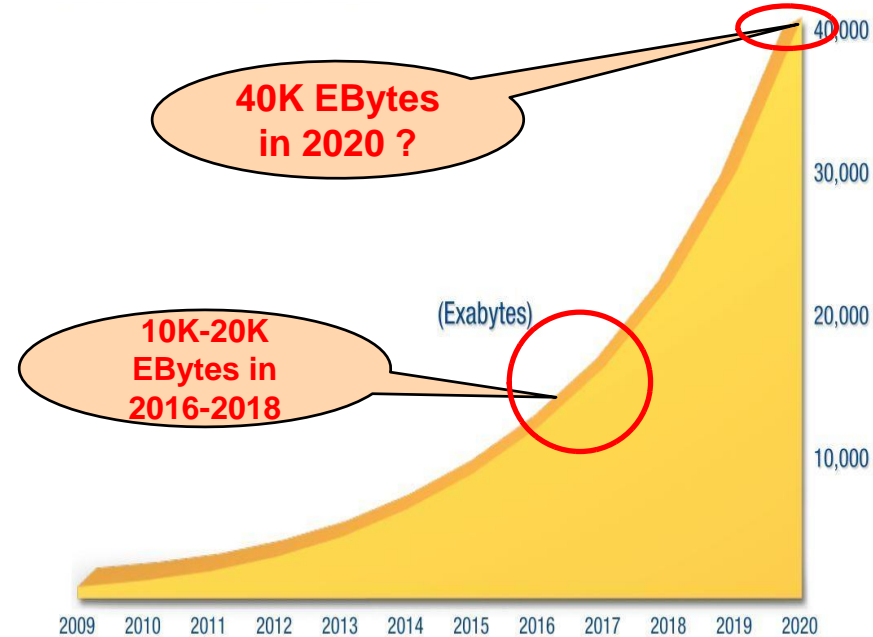

Source: IDC's Digital Universe Study, sponsored by EMC, December 2012

**ExaByte & BigData**

# Trends for Commodity Computing Clusters in the Top 500 List (<http://www.top500.org>)

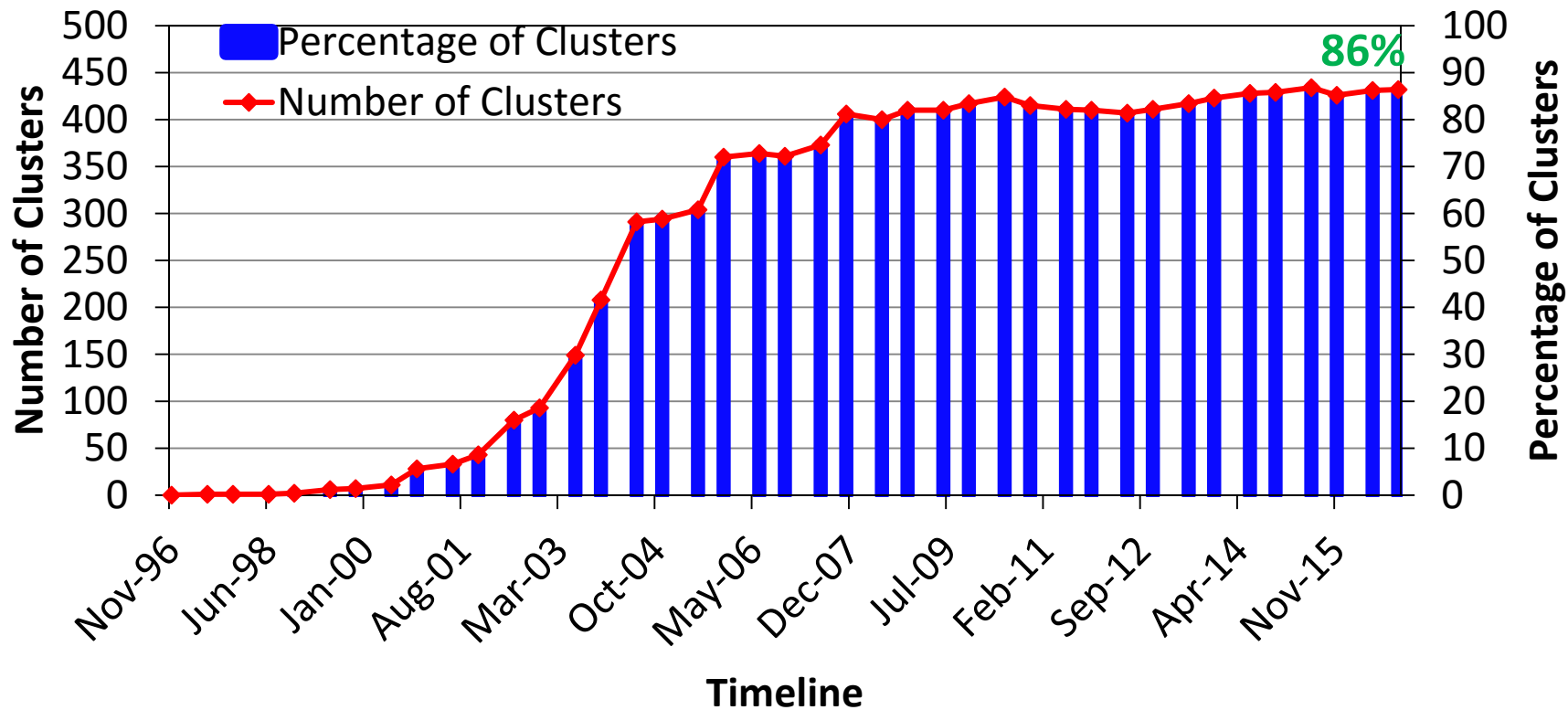

# Drivers of Modern HPC Cluster Architectures



Multi-core Processors



High Performance Interconnects -  
InfiniBand

<1usec latency, 100Gbps Bandwidth>



Accelerators / Coprocessors  
high compute density, high  
performance/watt  
>1 TFlop DP on a chip



SSD, NVMe-SSD, NVRAM

- Multi-core/many-core technologies
- Remote Direct Memory Access (RDMA)-enabled networking (InfiniBand and RoCE)
- Solid State Drives (SSDs), Non-Volatile Random-Access Memory (NVRAM), NVMe-SSD
- Accelerators (NVIDIA GPGPUs and Intel Xeon Phi)
- Available on HPC Clouds, e.g., Amazon EC2, NSF Chameleon, Microsoft Azure, etc.



*Sunway TaihuLight*



*K - Computer*



*Tianhe - 2*



*Titan*

# InfiniBand in the Top500 (Nov 2016)

## Number of Systems

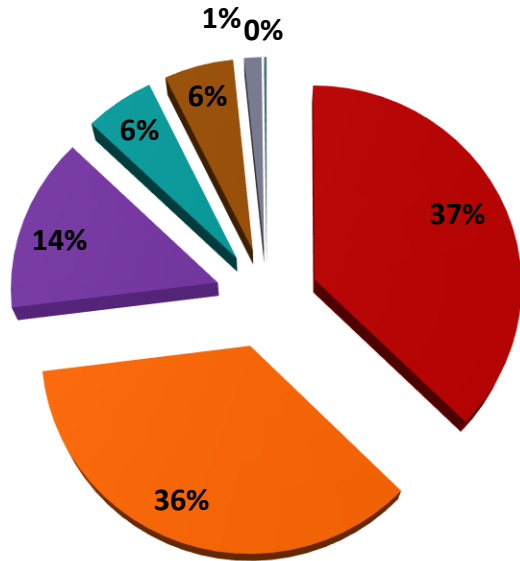

## Performance

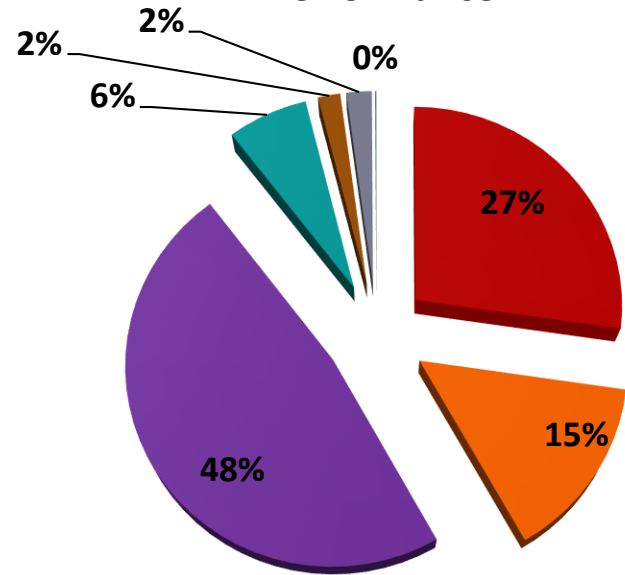

- InfiniBand
- Custom Interconnect
- Gigabit Ethernet
- Ethernet
- 10G
- Omnipath
- Proprietary Network

- InfiniBand
- Custom Interconnect
- Gigabit Ethernet
- Ethernet
- 10G
- Omnipath
- Proprietary Network

# Large-scale InfiniBand Installations

- 187 IB Clusters (37%) in the Nov'16 Top500 list
  - (<http://www.top500.org>)
- Installations in the Top 50 (15 systems):

<b>241,108 cores (Pleiades) at NASA/Ames (13<sup>th</sup>)</b>	147,456 cores (SuperMUC) in Germany (36 <sup>th</sup> )
220,800 cores (Pangea) in France (16 <sup>th</sup> )	86,016 cores (SuperMUC Phase 2) in Germany (37 <sup>th</sup> )
462,462 cores (Stampede) at TACC (17 <sup>th</sup> )	74,520 cores (Tsubame 2.5) at Japan/GSIC (40 <sup>th</sup> )
144,900 cores (Cheyenne) at NCAR/USA (20 <sup>th</sup> )	194,616 cores (Cascade) at PNNL (44 <sup>th</sup> )
72,800 cores Cray CS-Storm in US (25 <sup>th</sup> )	76,032 cores (Makman-2) at Saudi Aramco (49 <sup>th</sup> )
72,800 cores Cray CS-Storm in US (26 <sup>th</sup> )	72,000 cores (Prolix) at Meteo France, France (50 <sup>th</sup> )
124,200 cores (Topaz) SGI ICE at ERDC DSRC in US (27 <sup>th</sup> )	73,440 cores (Beaufix2) at Meteo France, France (51 <sup>st</sup> )
60,512 cores (DGX SATURNV) at NVIDIA/USA (28 <sup>th</sup> )	42,688 cores (Lomonosov-2) at Russia/MSU (52 <sup>nd</sup> )
72,000 cores (HPC2) in Italy (29 <sup>th</sup> )	60,240 cores SGI ICE X at JAEA Japan (54 <sup>th</sup> )
152,692 cores (Thunder) at AFRL/USA (32 <sup>nd</sup> )	<b>and many more!</b>

# Cloud Computing and Virtualization

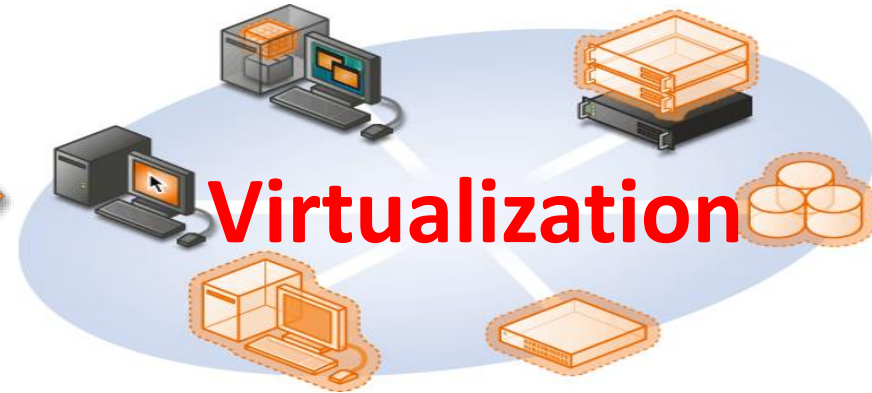

- Cloud Computing focuses on maximizing the effectiveness of the shared resources
- Virtualization is the key technology for resource sharing in the Cloud
- Widely adopted in industry computing environment
- IDC Forecasts Worldwide Public IT Cloud Services Spending to Reach Nearly \$108 Billion by 2017 (Courtesy: <http://www.idc.com/getdoc.jsp?containerId=prUS24298013>)

# HPC Cloud - Combining HPC with Cloud

- IDC expects that by 2017, HPC ecosystem revenue will jump to a record \$30.2 billion. IDC foresees public clouds, and especially custom public clouds, supporting an increasing proportion of the aggregate HPC workload as these cloud facilities grow more capable and mature (Courtesy: <http://www.idc.com/getdoc.jsp?containerId=247846>)
- Combining HPC with Cloud is still facing challenges because of the performance overhead associated virtualization support
  - **Lower performance of virtualized I/O devices**
- HPC Cloud Examples
  - **Amazon EC2 with Enhanced Networking**
    - Using Single Root I/O Virtualization (SR-IOV)
    - Higher performance (packets per second), lower latency, and lower jitter
    - 10 GigE
  - **NSF Chameleon Cloud**



# NSF Chameleon Cloud: A Powerful and Flexible Experimental Instrument



- Large-scale instrument
  - Targeting Big Data, Big Compute, Big Instrument research
  - ~650 nodes (~14,500 cores), 5 PB disk over two sites, 2 sites connected with 100G network
- Reconfigurable instrument
  - Bare metal reconfiguration, operated as single instrument, graduated approach for ease-of-use
- Connected instrument
  - Workload and Trace Archive
  - Partnerships with production clouds: CERN, OSDC, Rackspace, Google, and others
  - Partnerships with users
- Complementary instrument
  - Complementing GENI, Grid'5000, and other testbeds
- Sustainable instrument
  - Industry connections



<http://www.chameleoncloud.org/>



# Chameleon Hardware

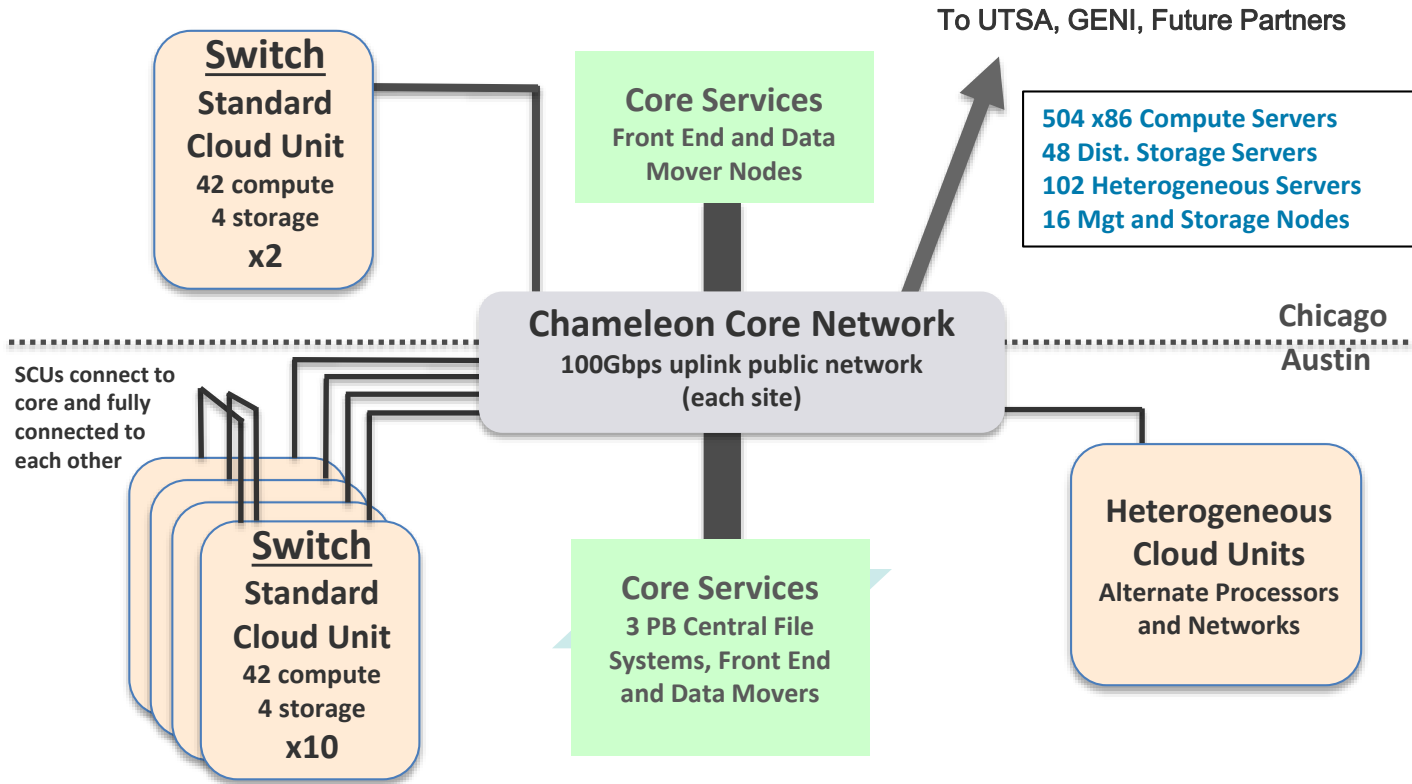

# Capabilities and Supported Research on Chameleon

Development of new models, algorithms, platforms, auto-scaling HA, etc., innovative application and educational uses

*Persistent, reliable, shared clouds*

Repeatable experiments in new models, algorithms, platforms, auto-scaling, high-availability, cloud federation, etc.

*Isolated partition, pre-configured images reconfiguration*

Virtualization technology (e.g., **SR-IOV**, accelerators), systems, networking, infrastructure-level resource management, etc.

*Isolated partition, full bare metal reconfiguration*

- SR-IOV + InfiniBand

# Single Root I/O Virtualization (SR-IOV)

- **Single Root I/O Virtualization (SR-IOV)** is providing new opportunities to design HPC cloud with very little low overhead
- Allows a single physical device, or a Physical Function (PF), to present itself as multiple virtual devices, or Virtual Functions (VFs)
- VFs are designed based on the existing non-virtualized PFs, no need for driver change
- Each VF can be dedicated to a single VM through PCI pass-through
- Work with 10/40 GigE and InfiniBand

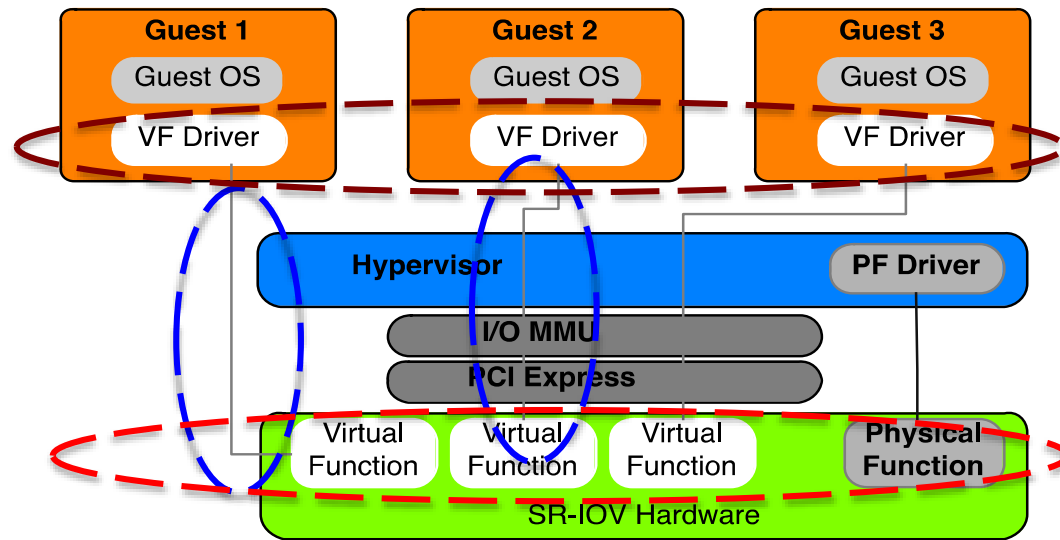

# Building HPC Cloud with SR-IOV and InfiniBand

- High-Performance Computing (HPC) has adopted advanced interconnects and protocols
  - InfiniBand
  - 10/40 Gigabit Ethernet/iWARP
  - RDMA over Converged Enhanced Ethernet (RoCE)
- Very Good Performance
  - Low latency (few micro seconds)
  - High Bandwidth (100 Gb/s with EDR InfiniBand)
  - Low CPU overhead (5-10%)
- OpenFabrics software stack with IB, iWARP and RoCE interfaces are driving HPC systems
- How to Build HPC Cloud with SR-IOV and InfiniBand for delivering optimal performance?

# HPC and Big Data on Cloud Computing Systems: Challenges

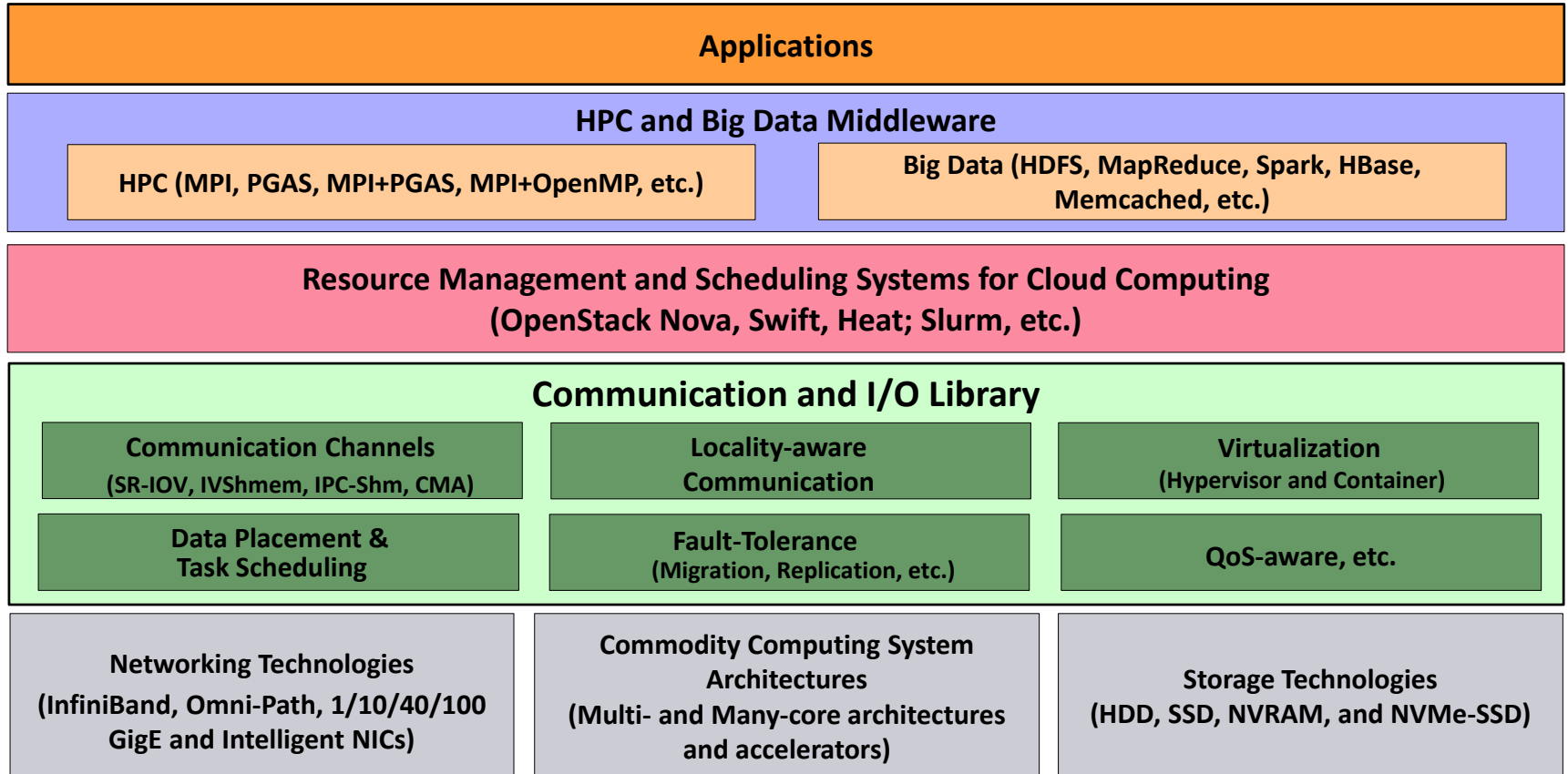

# Broad Challenges in Designing Communication and I/O Middleware for HPC on Clouds

- Virtualization Support with Virtual Machines and Containers
  - KVM, Docker, Singularity, etc.
- Communication coordination among optimized communication channels on Clouds
  - SR-IOV, IVShmem, IPC-Shm, CMA, etc.
- Locality-aware communication
- Scalability for million processors
  - Support for highly-efficient inter-node and intra-node communication (both two-sided and one-sided)
- Scalable Collective communication
  - Offload
  - Non-blocking
  - Topology-aware
- Balancing intra-node and inter-node communication for next generation nodes (128-1024 cores)
  - Multiple end-points per node
- Support for efficient multi-threading
- Integrated Support for GPGPUs and Accelerators
- Fault-tolerance/resiliency
  - Migration support with virtual machines
- QoS support for communication and I/O
- Support for Hybrid MPI+PGAS programming (MPI + OpenMP, MPI + UPC, MPI + OpenSHMEM, MPI+UPC++, CAF, ...)
- Energy-Awareness
- Co-design with resource management and scheduling systems on Clouds
  - OpenStack, Slurm, etc.

# Additional Challenges in Designing Communication and I/O Middleware for Big Data on Clouds

- High-Performance designs for Big Data middleware
  - RDMA-based designs to accelerate Big Data middleware on high-performance Interconnects
  - NVM-aware communication and I/O schemes for Big Data
  - SATA-/PCIe-/NVMe-SSD support
  - Parallel Filesystems support
  - Optimized overlapping among Computation, Communication, and I/O
  - Threaded Models and Synchronization
- Fault-tolerance/resiliency
  - Migration support with virtual machines
  - Data replication
- Efficient data access and placement policies
- Efficient task scheduling
- Fast deployment and automatic configurations on Clouds



# Approaches to Build HPC Clouds

- MVAPICH2-Virt with SR-IOV and IVSHMEM
  - Standalone, OpenStack
- MVAPICH2 with Containers
- MVAPICH2-Virt on SLURM
  - SLURM alone, SLURM + OpenStack
- Big Data Libraries on Cloud

# Overview of the MVAPICH2 Project

- High Performance open-source MPI Library for InfiniBand, Omni-Path, Ethernet/iWARP, and RDMA over Converged Ethernet (RoCE)
  - MVAPICH (MPI-1), MVAPICH2 (MPI-2.2 and MPI-3.0), Started in 2001, First version available in 2002
  - MVAPICH2-X (MPI + PGAS), Available since 2011
  - Support for GPGPUs (MVAPICH2-GDR) and MIC (MVAPICH2-MIC), Available since 2014
  - **Support for Virtualization (MVAPICH2-Virt), Available since 2015**
  - Support for Energy-Awareness (MVAPICH2-EA), Available since 2015
  - Support for InfiniBand Network Analysis and Monitoring (OSU INAM) since 2015
  - **Used by more than 2,700 organizations in 83 countries**
  - **More than 404,000 (> 0.4 million) downloads from the OSU site directly**
  - Empowering many TOP500 clusters (Nov '16 ranking)
    - **1<sup>st</sup> ranked 10,649,640-core cluster (Sunway TaihuLight) at NSC, Wuxi, China**
    - 13<sup>th</sup> ranked 241,108-core cluster (Pleiades) at NASA
    - 17<sup>th</sup> ranked 519,640-core cluster (Stampede) at TACC
    - 40<sup>th</sup> ranked 76,032-core cluster (Tsubame 2.5) at Tokyo Institute of Technology and many others
  - Available with software stacks of many vendors and Linux Distros (RedHat and SuSE)
  - <http://mvapich.cse.ohio-state.edu>
- Empowering Top500 systems for over a decade
  - System-X from Virginia Tech (3<sup>rd</sup> in Nov 2003, 2,200 processors, 12.25 TFlops) ->  
Sunway TaihuLight at NSC, Wuxi, China (1<sup>st</sup> in Nov'16, 10,649,640 cores, 93 PFlops)



# MVAPICH2 Release Timeline and Downloads

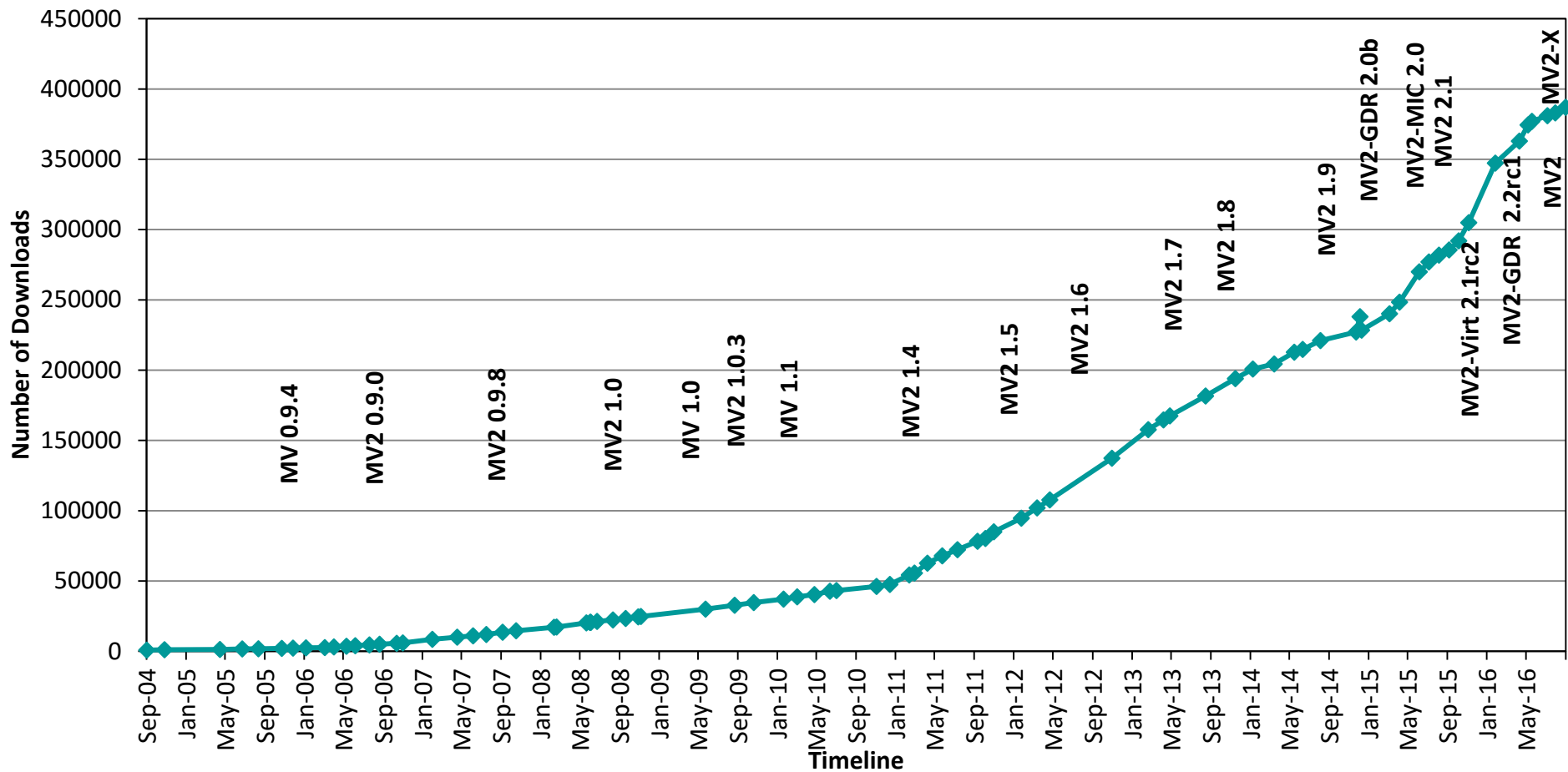

# MVAPICH2 Architecture

## High Performance Parallel Programming Models

**Message Passing Interface  
(MPI)**

**PGAS  
(UPC, OpenSHMEM, CAF, UPC++)**

**Hybrid --- MPI + X  
(MPI + PGAS + OpenMP/Cilk)**

## High Performance and Scalable Communication Runtime

### Diverse APIs and Mechanisms

Point-to-point  
Primitives

Collectives  
Algorithms

Job Startup

Energy-  
Awareness

Remote  
Memory  
Access

I/O and  
File Systems

Fault  
Tolerance

Virtualization

Active  
Messages

Introspection  
& Analysis

### Support for Modern Networking Technology (InfiniBand, iWARP, RoCE, OmniPath)

#### Transport Protocols

RC

XRC

UD

DC

#### Modern Features

UMR

ODP

SR-  
IOV

Multi  
Rail

### Support for Modern Multi-/Many-core Architectures (Intel-Xeon, OpenPower, Xeon-Phi (MIC, KNL), NVIDIA GPGPU)

#### Transport Mechanisms

Shared  
Memory

CMA

IVSHMEM

#### Modern Features

MCDRAM\*

NVLink\*

CAPI\*

\* **Upcoming**

# MVAPICH2 Software Family

High-Performance Parallel Programming Libraries	
MVAPICH2	Support for InfiniBand, Omni-Path, Ethernet/iWARP, and RoCE
MVAPICH2-X	Advanced MPI features, OSU INAM, PGAS (OpenSHMEM, UPC, UPC++, and CAF), and MPI+PGAS programming models with unified communication runtime
MVAPICH2-GDR	Optimized MPI for clusters with NVIDIA GPUs
 MVAPICH2-Virt	<b>High-performance and scalable MPI for hypervisor and container based HPC cloud</b>
MVAPICH2-EA	Energy aware and High-performance MPI
MVAPICH2-MIC	Optimized MPI for clusters with Intel KNC
Microbenchmarks	
OMB	Microbenchmarks suite to evaluate MPI and PGAS (OpenSHMEM, UPC, and UPC++) libraries for CPUs and GPUs
Tools	
OSU INAM	Network monitoring, profiling, and analysis for clusters with MPI and scheduler integration
OEMT	Utility to measure the energy consumption of MPI applications

# HPC on Cloud Computing Systems: Challenges Addressed by OSU So Far

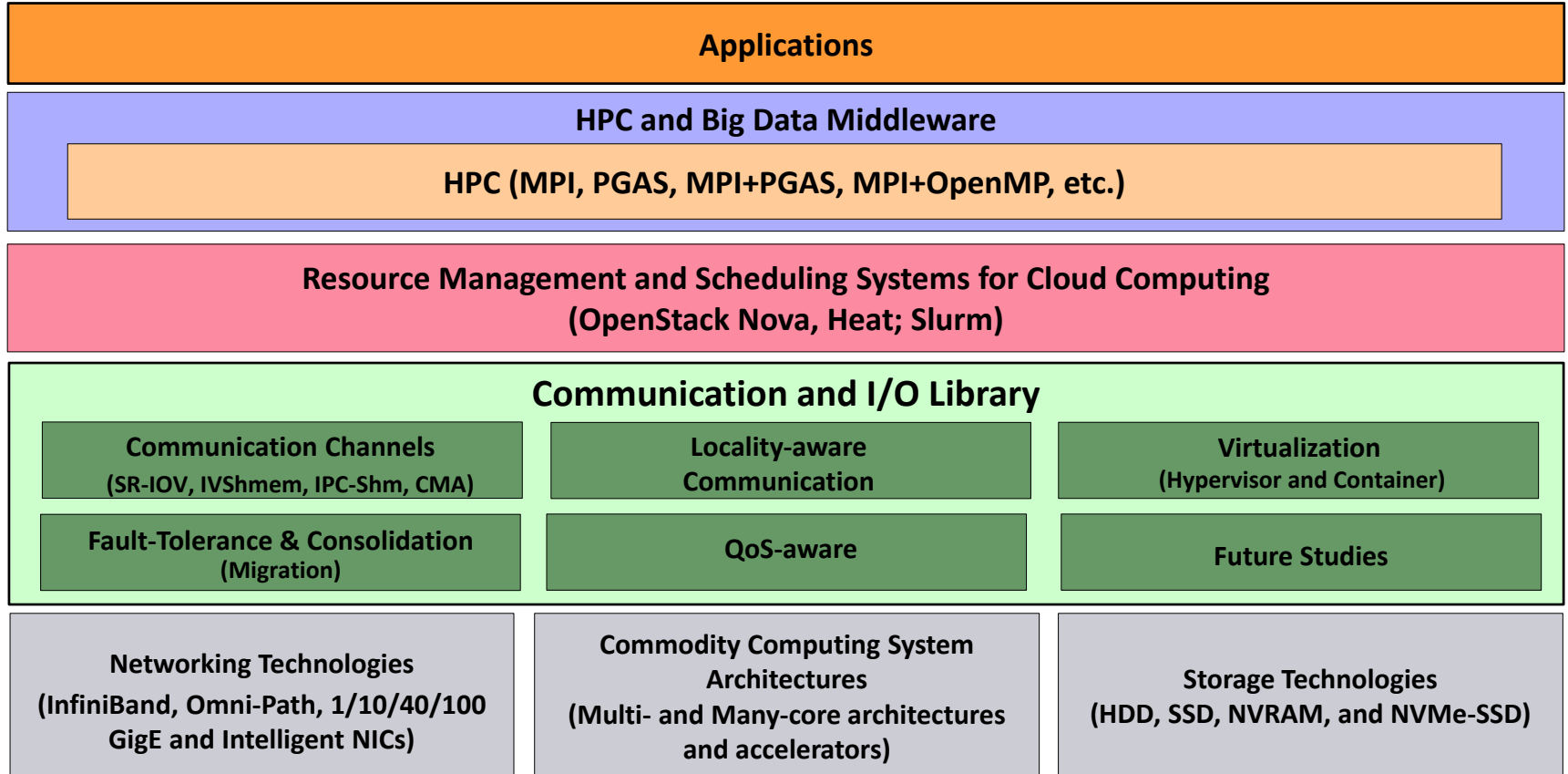

# Overview of MVAPICH2-Virt with SR-IOV and IVSHMEM

- Redesign MVAPICH2 to make it virtual machine aware
  - SR-IOV shows **near to native performance** for inter-node point to point communication
  - **IVSHMEM** offers **shared memory** based data access across co-resident VMs
  - **Locality Detector**: maintains the locality information of co-resident virtual machines
  - **Communication Coordinator**: selects the communication channel (SR-IOV, IVSHMEM) adaptively

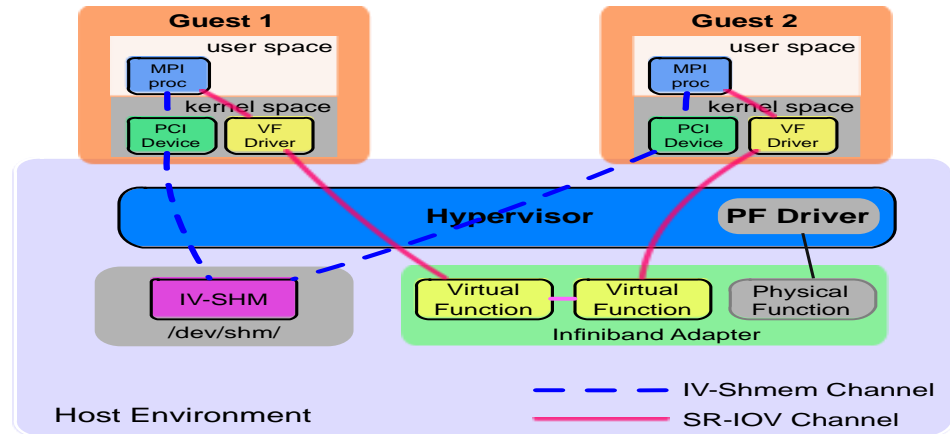

J. Zhang, X. Lu, J. Jose, R. Shi, D. K. Panda. Can Inter-VM Shmem Benefit MPI Applications on SR-IOV based Virtualized InfiniBand Clusters? Euro-Par, 2014

J. Zhang, X. Lu, J. Jose, R. Shi, M. Li, D. K. Panda. High Performance MPI Library over SR-IOV Enabled InfiniBand Clusters. HiPC, 2014

# MVAPICH2-Virt with SR-IOV and IVSHMEM over OpenStack

- OpenStack is one of the most popular open-source solutions to build clouds and manage virtual machines
- Deployment with OpenStack
  - Supporting SR-IOV configuration
  - Supporting IVSHMEM configuration
  - Virtual Machine aware design of MVAPICH2 with SR-IOV
- An efficient approach to build HPC Clouds with MVAPICH2-Virt and OpenStack

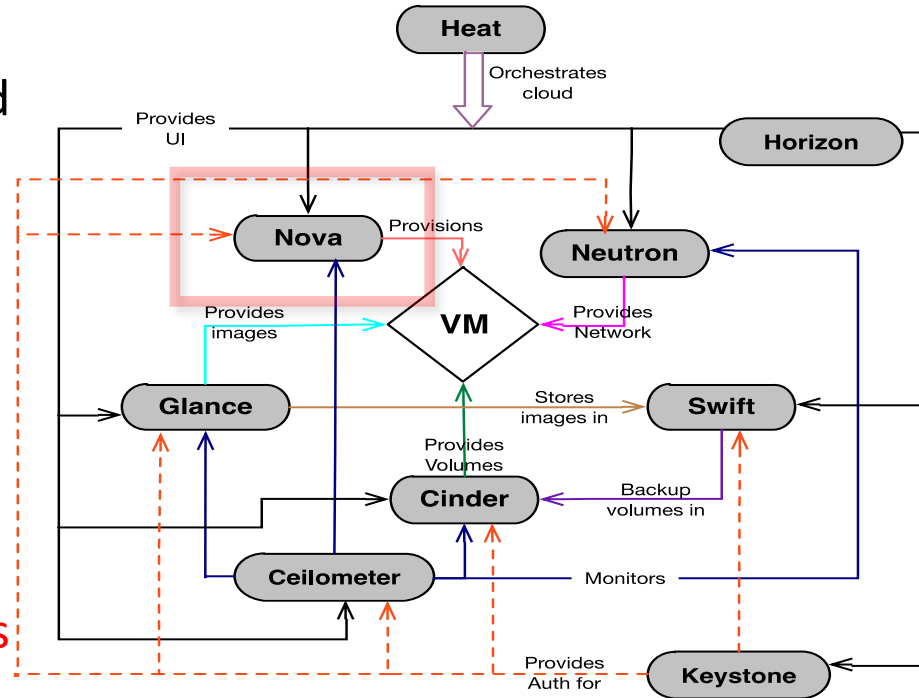

J. Zhang, X. Lu, M. Arnold, D. K. Panda. MVAPICH2 over OpenStack with SR-IOV: An Efficient Approach to Build HPC Clouds. CCGrid, 2015



# Performance Evaluation

Cluster	Nowlab Cloud		Amazon EC2	
Instance	4 Core/VM	8 Core/VM	4 Core/VM	8 Core/VM
Platform	RHEL 6.5 Qemu+KVM HVM SLURM 14.11.8		Amazon Linux (EL6) Xen HVM C3.xlarge <sup>[1]</sup> Instance	Amazon Linux (EL6) Xen HVM C3.2xlarge <sup>[1]</sup> Instance
CPU	SandyBridge Intel(R) Xeon E5-2670 (2.6GHz)		IvyBridge Intel(R) Xeon E5-2680v2 (2.8GHz)	
RAM	6 GB	12 GB	7.5 GB	15 GB
Interconnect	FDR (56Gbps) InfiniBand Mellanox ConnectX-3 with SR-IOV <sup>[2]</sup>		10 GigE with Intel ixgbevf SR-IOV driver <sup>[2]</sup>	

<sup>[1]</sup> Amazon EC2 C3 instances: compute-optimized instances, providing customers with the highest performing processors, good for HPC workloads

<sup>[2]</sup> Nowlab Cloud is using InfiniBand FDR (56Gbps), while Amazon EC2 C3 instances are using 10 GigE. Both have SR-IOV

# Experiments Carried Out

- Point-to-point
  - Two-sided and One-sided
  - Latency and Bandwidth
  - Intra-node and Inter-node <sup>[1]</sup>
- Applications
  - NAS and Graph500

[1] Amazon EC2 does not support users to explicitly allocate VMs in one physical node so far. We allocate multiple VMs in one logical group and compare the point-to-point performance for each pair of VMs. We see the VMs who have the lowest latency as located within one physical node (Intra-node), otherwise Inter-node.

# Point-to-Point Performance – Latency & Bandwidth (Intra-node)

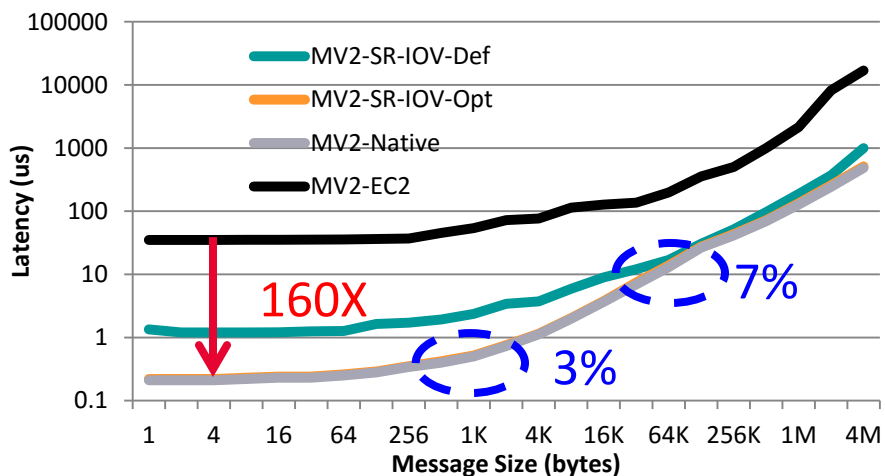

Intra-node Inter-VM pt2pt Latency

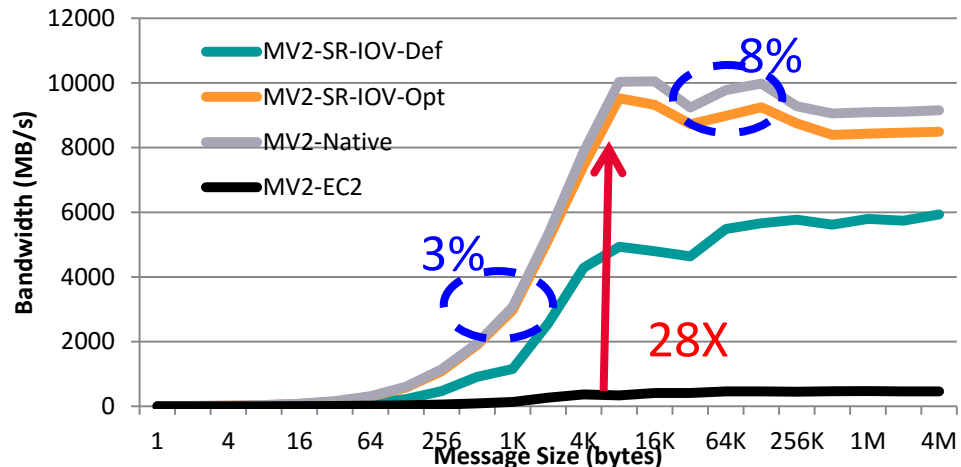

Intra-node Inter-VM pt2pt Bandwidth

- EC2 C3.2xlarge instances
- Compared to SR-IOV-Def, up to **84%** and **158%** performance improvement on Lat & BW
- Compared to Native, **3%-7%** overhead for Lat, **3%-8%** overhead for BW
- Compared to EC2, up to **160X** and **28X** performance speedup on Lat & BW

# Point-to-Point Performance – Latency & Bandwidth (Inter-node)

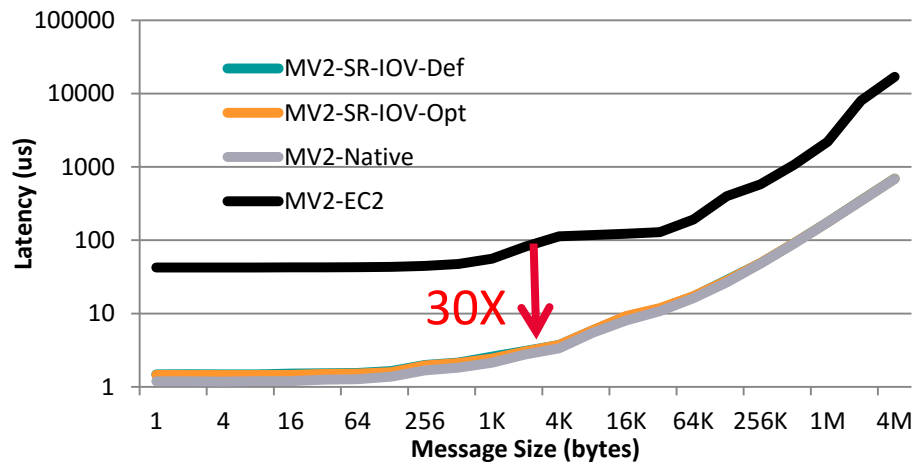

Inter-node Inter-VM pt2pt Latency

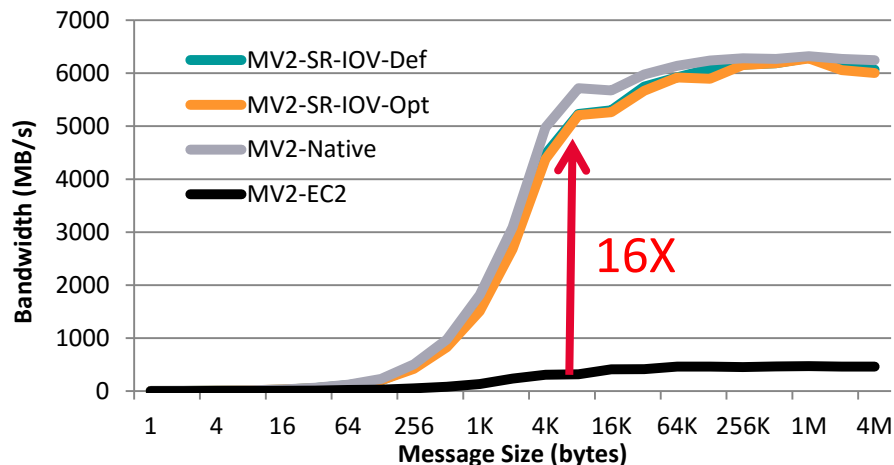

Inter-node Inter-VM pt2pt Bandwidth

- EC2 C3.2xlarge instances
- Similar performance with SR-IOV-Def
- Compared to Native, 2%-8% overhead on Lat & BW for 8KB+ messages
- Compared to EC2, up to 30X and 16X performance speedup on Lat & BW

# Application-Level Performance (8 VM \* 8 Core/VM)

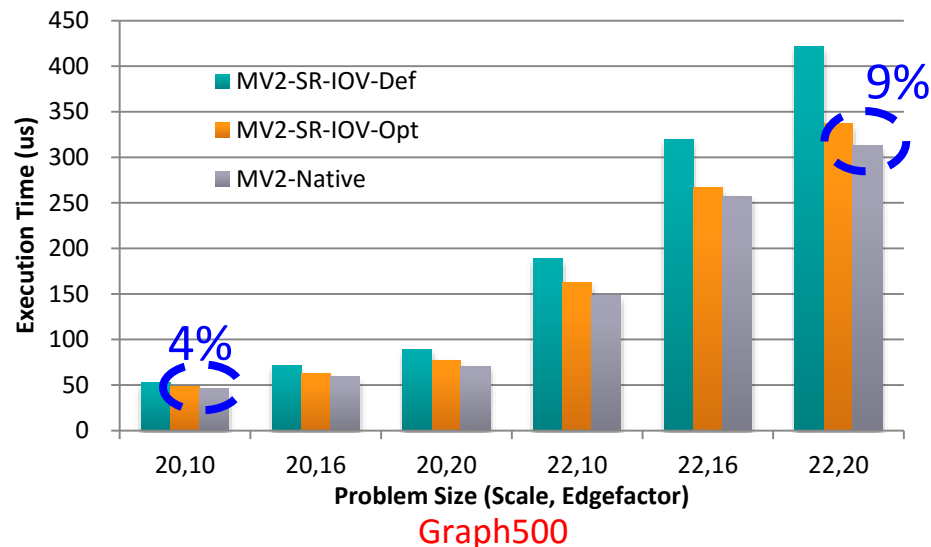
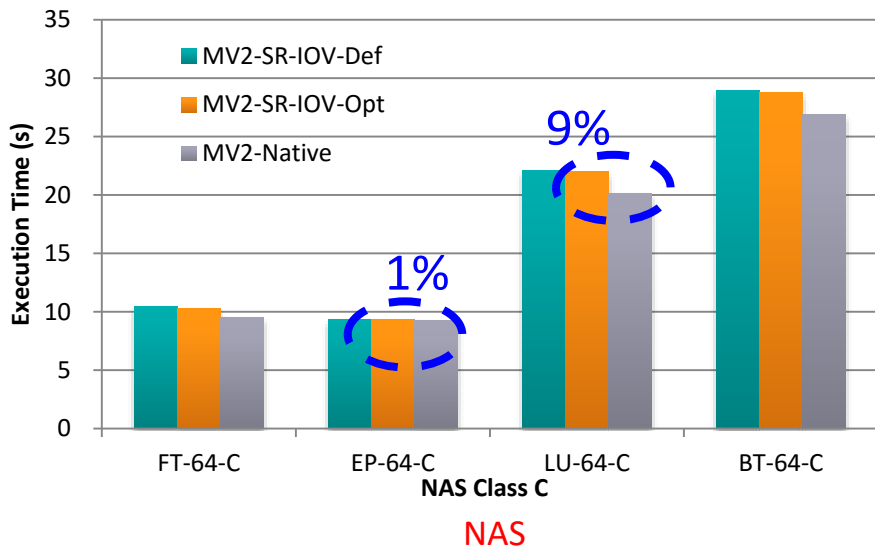

- Compared to Native, 1-9% overhead for NAS
- Compared to Native, 4-9% overhead for Graph500

# Application-Level Performance on Chameleon

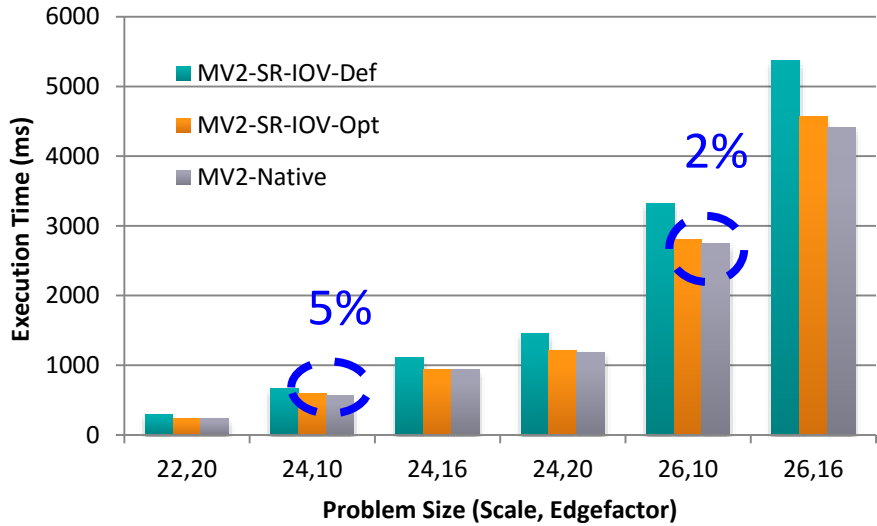

Graph500

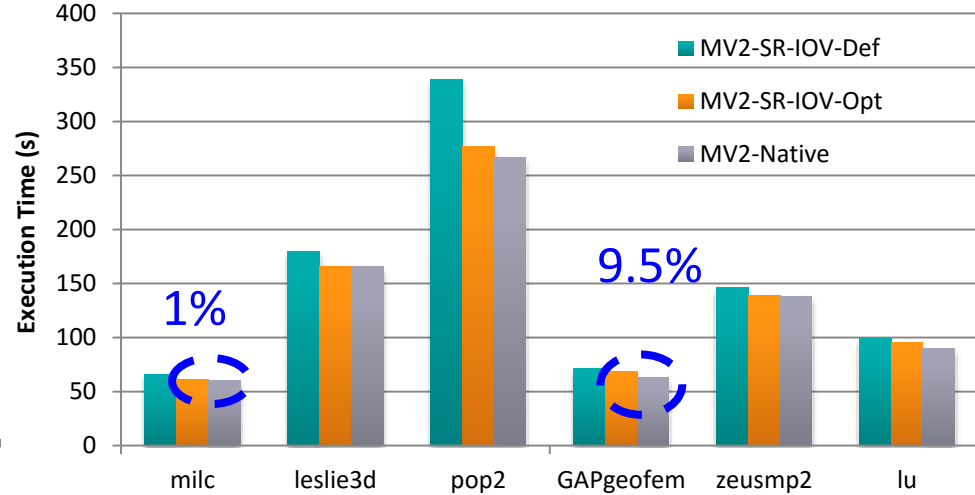

SPEC MPI2007

- 32 VMs, 6 Core/VM
- Compared to Native, 2-5% overhead for Graph500 with 128 Procs
- Compared to Native, 1-9.5% overhead for SPEC MPI2007 with 128 Procs

# Approaches to Build HPC Clouds

- MVAPICH2-Virt with SR-IOV and IVSHMEM
  - Standalone, OpenStack
- **MVAPICH2 with Containers**
- MVAPICH2-Virt on SLURM
  - SLURM alone, SLURM + OpenStack
- Big Data Libraries on Cloud

# Overview of Containers-based Virtualization

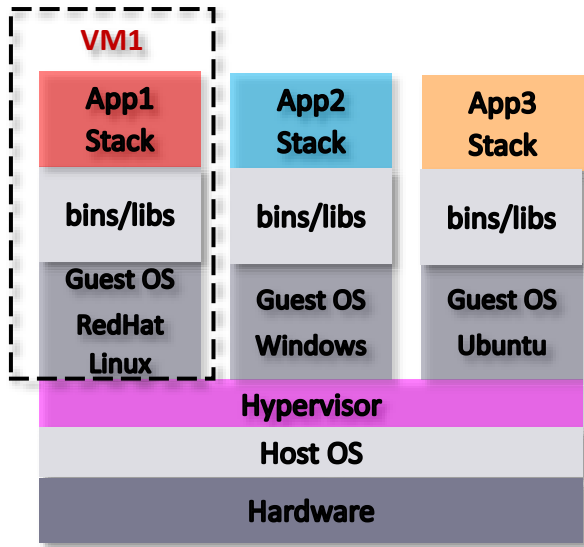

Hypervisor-based Virtualization

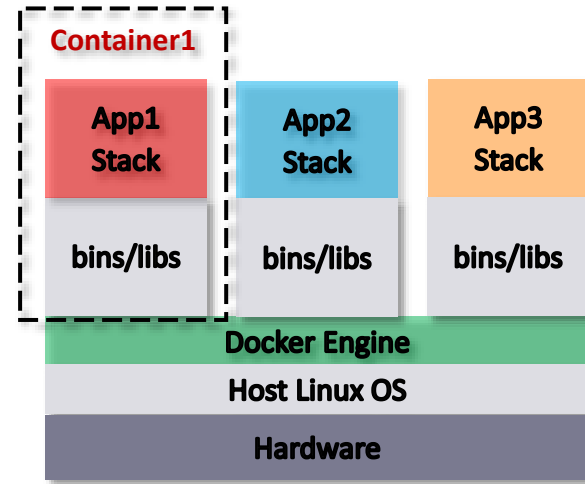

Container-based Virtualization

- Container-based technologies (e.g., Docker) provide **lightweight** virtualization solutions
- Container-based virtualization – share host kernel by containers



# Benefits of Containers-based Virtualization for HPC on Cloud

ib\_send\_lat

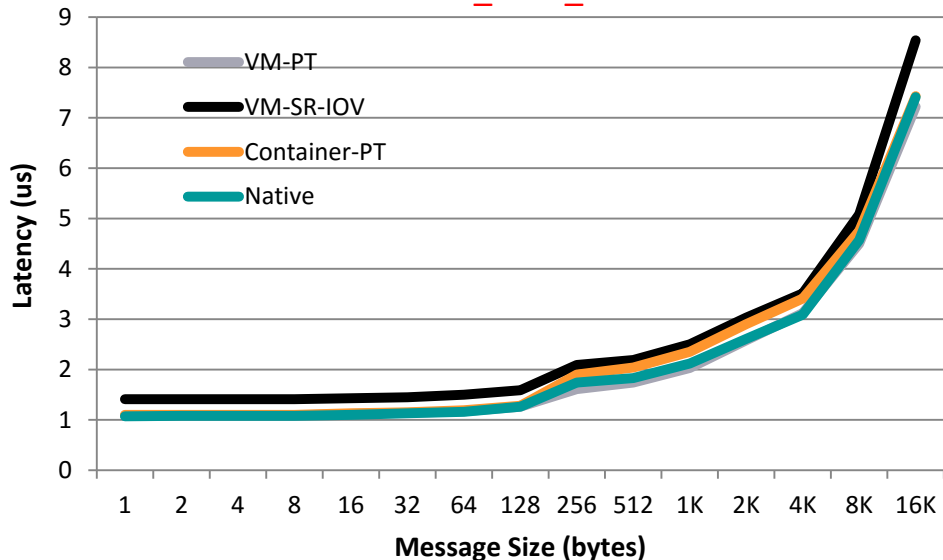

Graph500

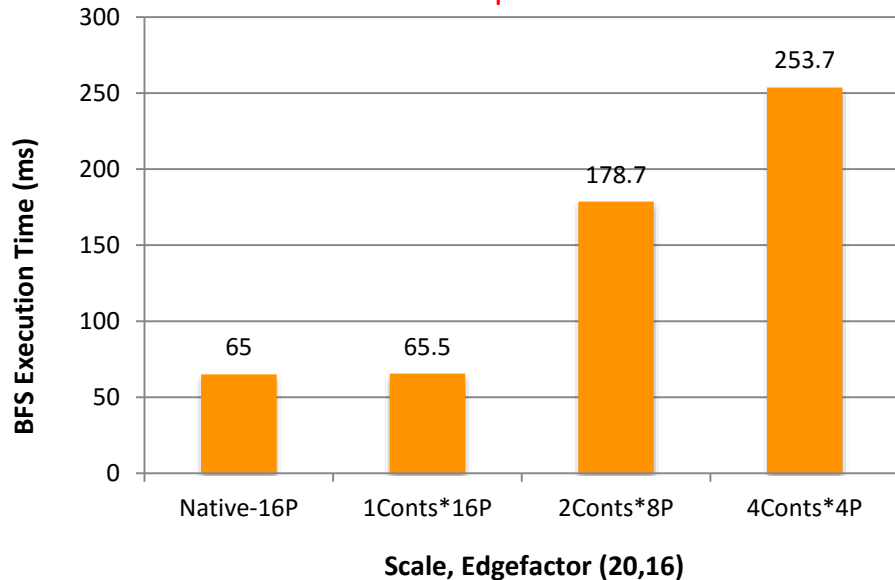

- Experiment on NFS Chameleon Cloud
- Container has less overhead than VM
- BFS time in Graph 500 significantly increases as the number of container increases on a host. **Why?**

J. Zhang, X. Lu, D. K. Panda. Performance Characterization of Hypervisor- and Container-Based Virtualization for HPC on SR-IOV Enabled InfiniBand Clusters. IPDRM, IPDPS Workshop, 2016

# Containers-based Design: Issues, Challenges, and Approaches

- What are the performance **bottlenecks** when running MPI applications on multiple containers per host in HPC cloud?
- Can we propose a new design to overcome the bottleneck on such container-based HPC cloud?
- Can optimized design deliver **near-native performance** for different container deployment scenarios?
- **Locality-aware** based design to enable **CMA** and **Shared memory** channels for MPI communication across co-resident containers

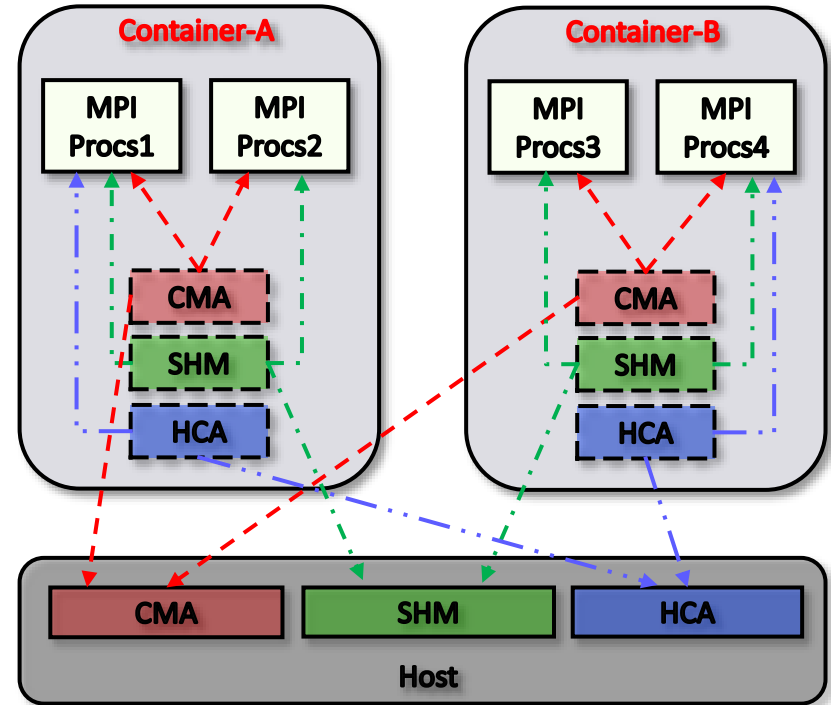

J. Zhang, X. Lu, D. K. Panda. High Performance MPI Library for Container-based HPC Cloud on InfiniBand Clusters. ICPP, 2016

# Containers Support: MVAPICH2 Intra-node Inter-Container Point-to-Point Performance on Chameleon

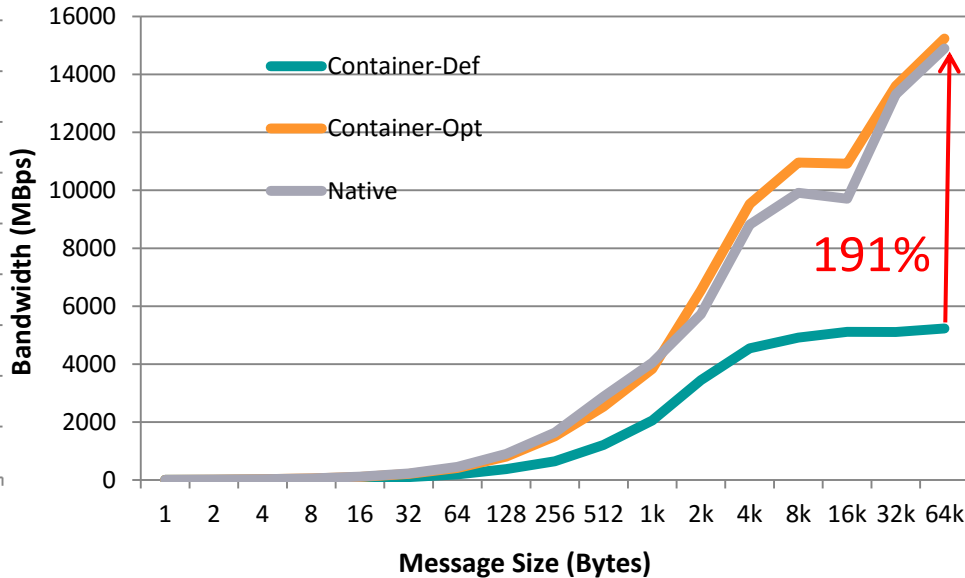
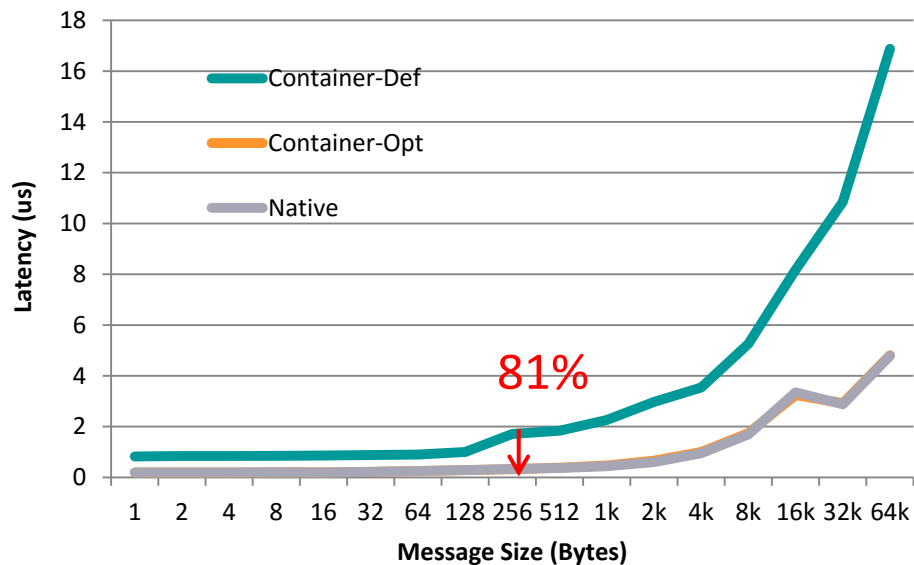

- Intra-Node Inter-Container
- Compared to Container-Def, up to 81% and 191% improvement on Latency and BW
- Compared to Native, minor overhead on Latency and BW

# Containers Support: MVAPICH2 Collective Performance on Chameleon

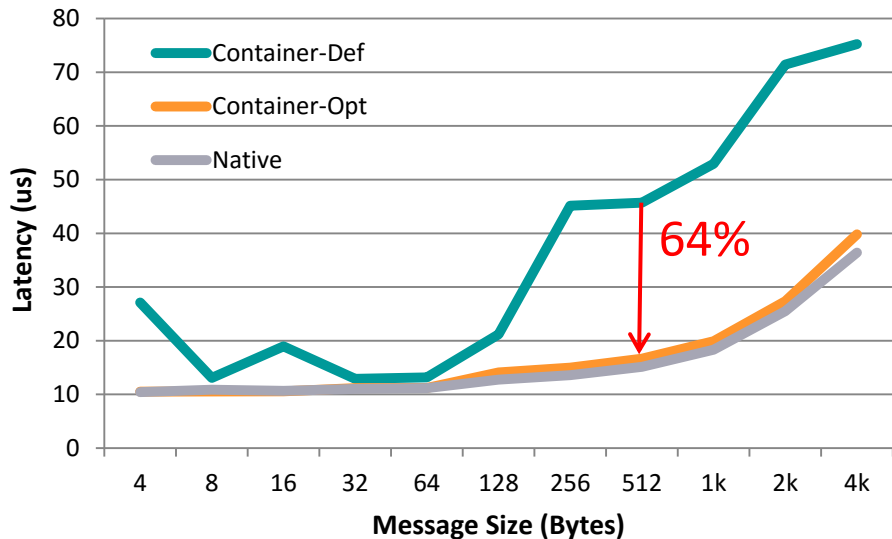

Allreduce

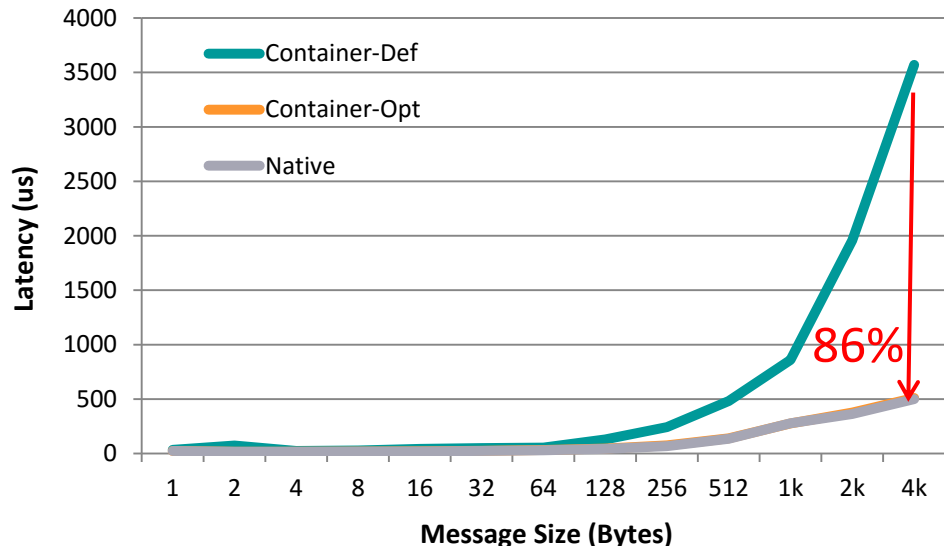

Allgather

- 64 Containers across 16 nodes, pinning 4 Cores per Container
- Compared to Container-Def, up to 64% and 86% improvement on Allreduce and Allgather
- Compared to Native, minor overhead on Allreduce and Allgather

# Containers Support: Application-Level Performance on Chameleon

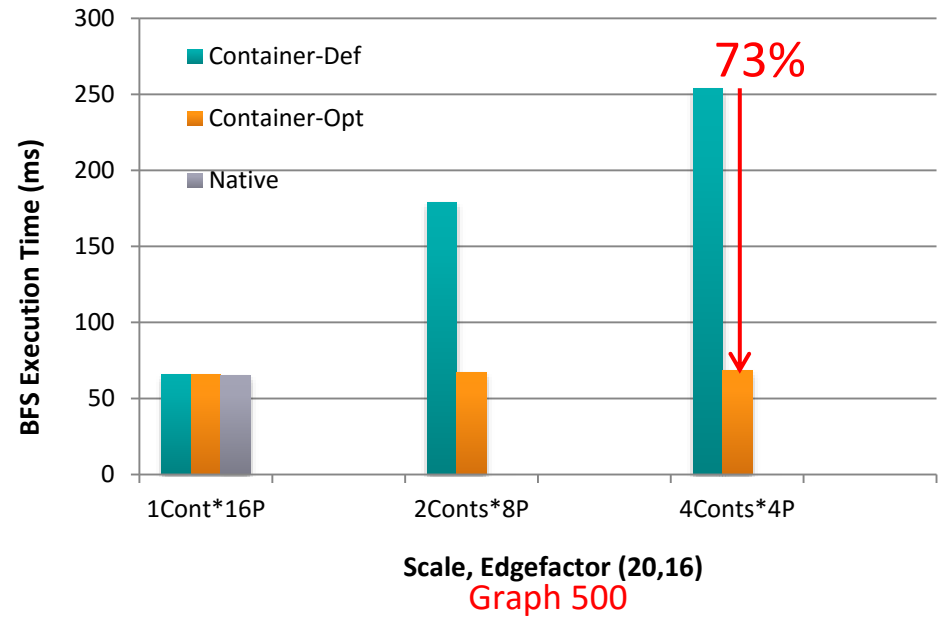
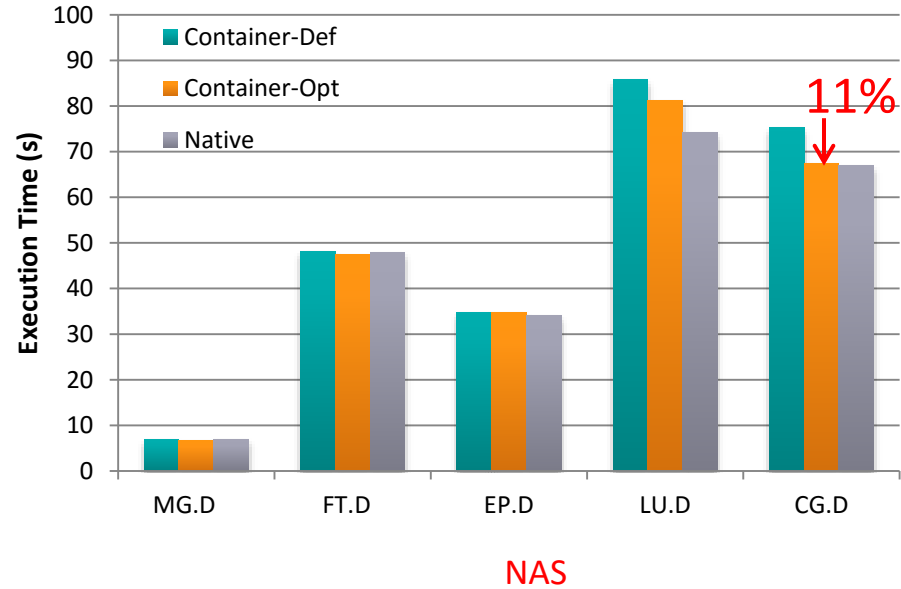

- 64 Containers across 16 nodes, pinning 4 Cores per Container
- Compared to Container-Def, up to **11%** and **73%** of execution time reduction for NAS and Graph 500
- Compared to Native, less than **9%** and **5%** overhead for NAS and Graph 500

# MVAPICH2-Virt 2.2rc1

- Major Features and Enhancements
  - Based on MVAPICH2 2.2rc1
  - Support for efficient MPI communication over SR-IOV enabled InfiniBand networks
  - High-performance and locality-aware MPI communication with IVSHMEM for virtual machines
  - High-performance and locality-aware MPI communication with IPC-SHM and CMA for containers
  - Support for auto-detection of IVSHMEM device in virtual machines
  - Support for locality auto-detection in containers
  - Automatic communication channel selection among SR-IOV, IVSHMEM, and CMA/LIMIC2 in virtual machines
  - Automatic communication channel selection among IPC-SHM, CMA, and HCA in containers
  - Support for integration with OpenStack
  - Support for easy configuration through runtime parameters
  - Tested with
    - Docker 1.9.1 and 1.10.3
    - Mellanox InfiniBand adapters (ConnectX-3 (56Gbps))
    - OpenStack Juno
  - Available from <http://mvapich.cse.ohio-state.edu>
  - Will be updated to the latest MVAPICH2 2.2 GA version soon

# Approaches to Build HPC Clouds

- MVAPICH2-Virt with SR-IOV and IVSHMEM
  - Standalone, OpenStack
- MVAPICH2 with Containers
- **MVAPICH2-Virt on SLURM**
  - **SLURM alone, SLURM + OpenStack**
- Big Data Libraries on Cloud

# Can HPC Clouds be built with MVAPICH2-Virt on SLURM?

- SLURM is one of the most popular open-source solutions to manage huge amounts of machines in HPC clusters.
- How to **build a SLURM-based HPC Cloud with near native performance** for MPI applications over SR-IOV enabled InfiniBand HPC clusters?
- What are the **requirements** on SLURM to support SR-IOV and IVSHMEM provided in **HPC Clouds**?
- How much **performance benefit** can be achieved on MPI primitive operations and applications in **“MVAPICH2-Virt on SLURM”-based HPC clouds**?

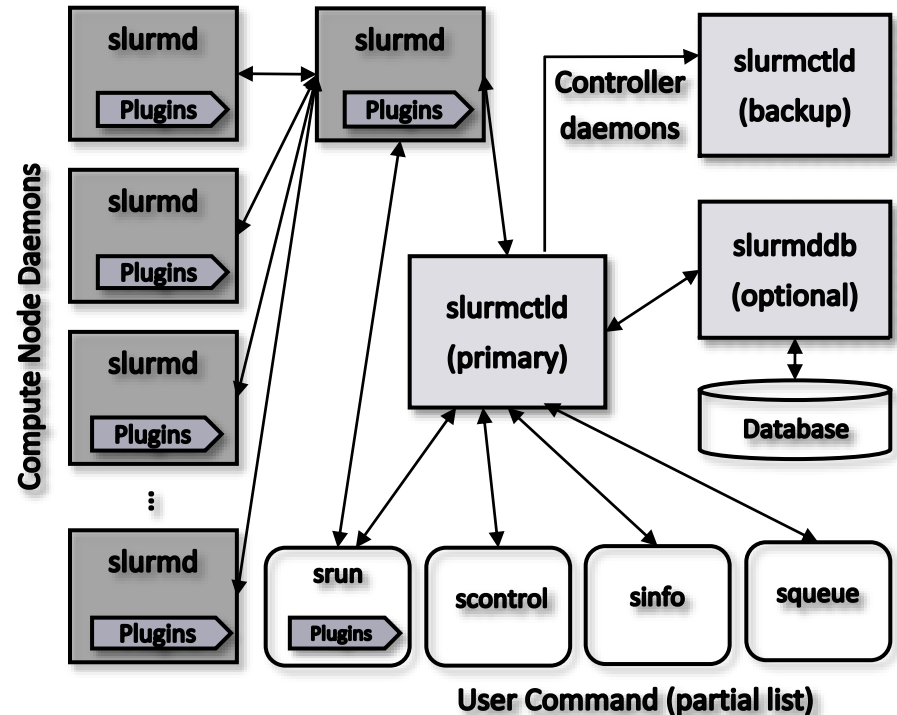



# Typical Usage Scenarios

Compute Nodes

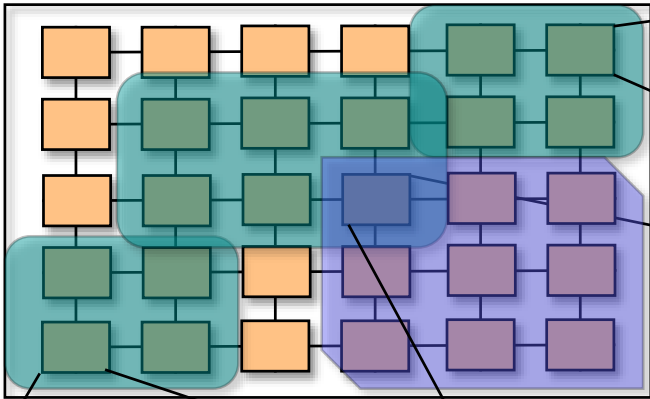

Exclusive Allocations  
Concurrent Jobs

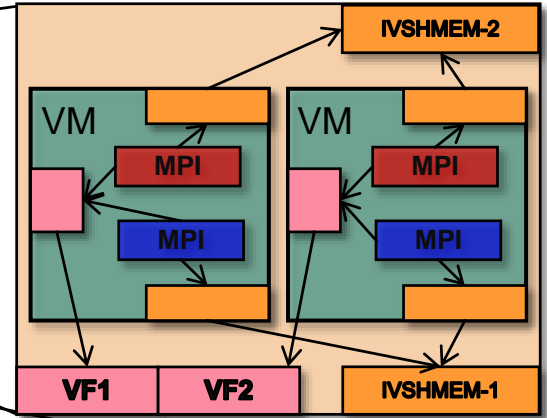

Exclusive Allocations  
Sequential Jobs

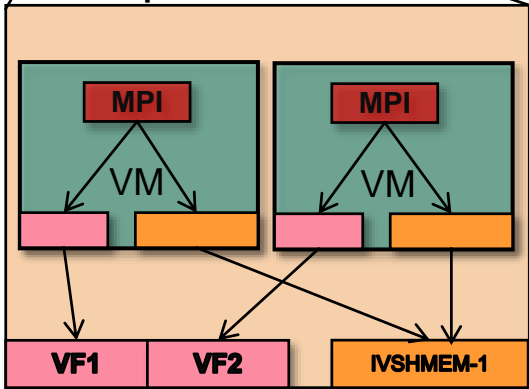

Shared-host Allocations  
Concurrent Jobs

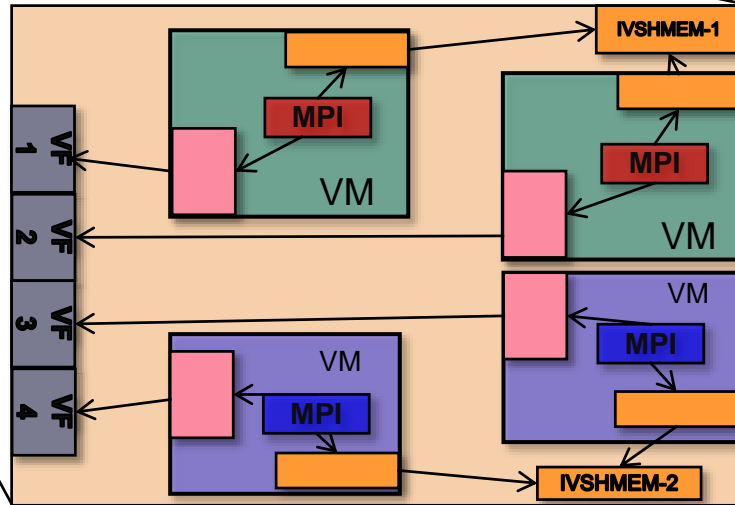

# Need for Supporting SR-IOV and IVSHMEM in SLURM

- Requirement of managing and isolating virtualized resources of SR-IOV and IVSHMEM
- Such kind of management and isolation is hard to be achieved by MPI library alone, **but much easier with SLURM**
- **Efficient running MPI applications on HPC Clouds needs SLURM to support managing SR-IOV and IVSHMEM**
  - Can critical HPC resources be efficiently shared among users by extending SLURM with support for SR-IOV and IVSHMEM based virtualization?
  - Can SR-IOV and IVSHMEM enabled SLURM and MPI library provide bare-metal performance for end applications on HPC Clouds?

# Workflow of Running MPI Jobs with MVAPICH2-Virt on SLURM

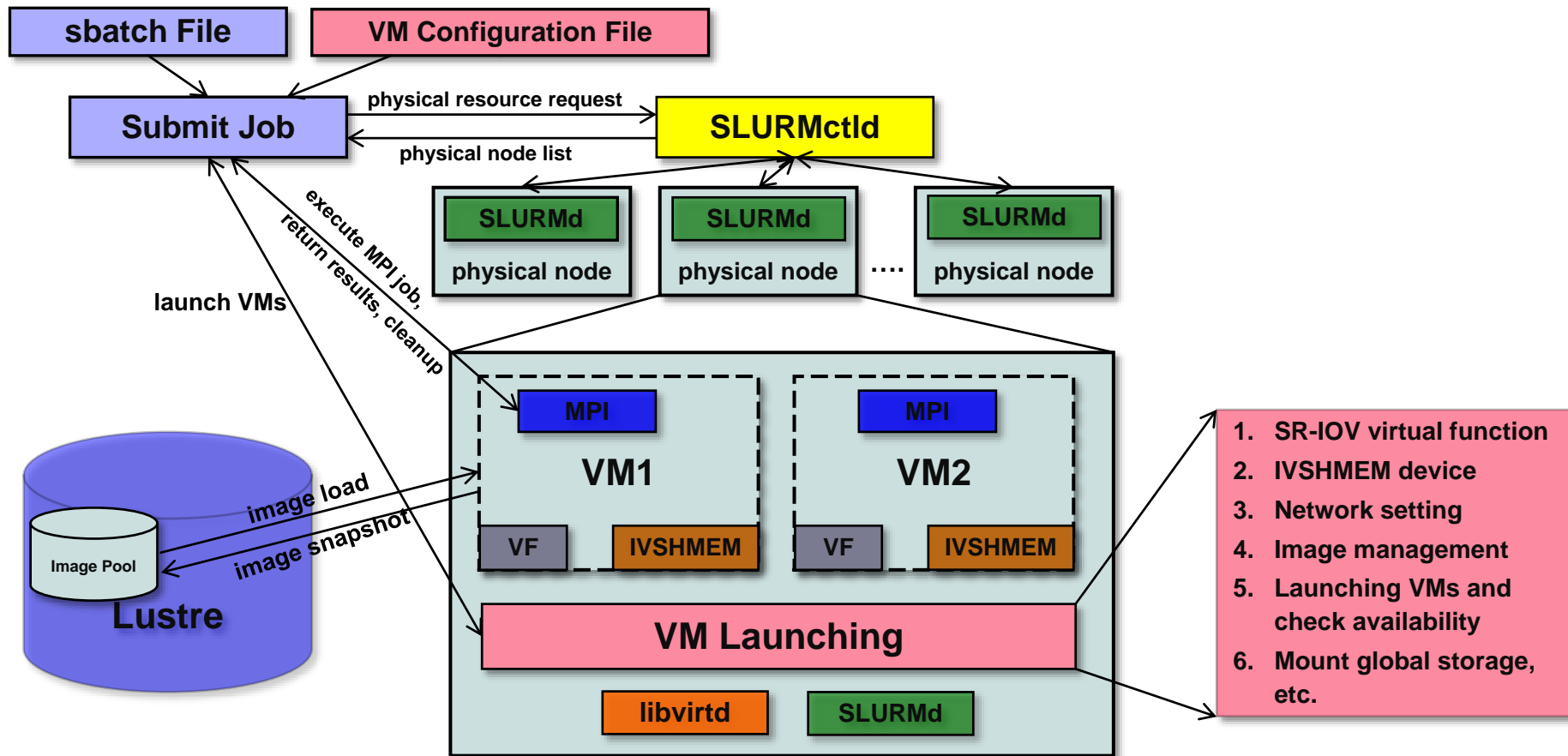

# SLURM SPANK Plugin based Design

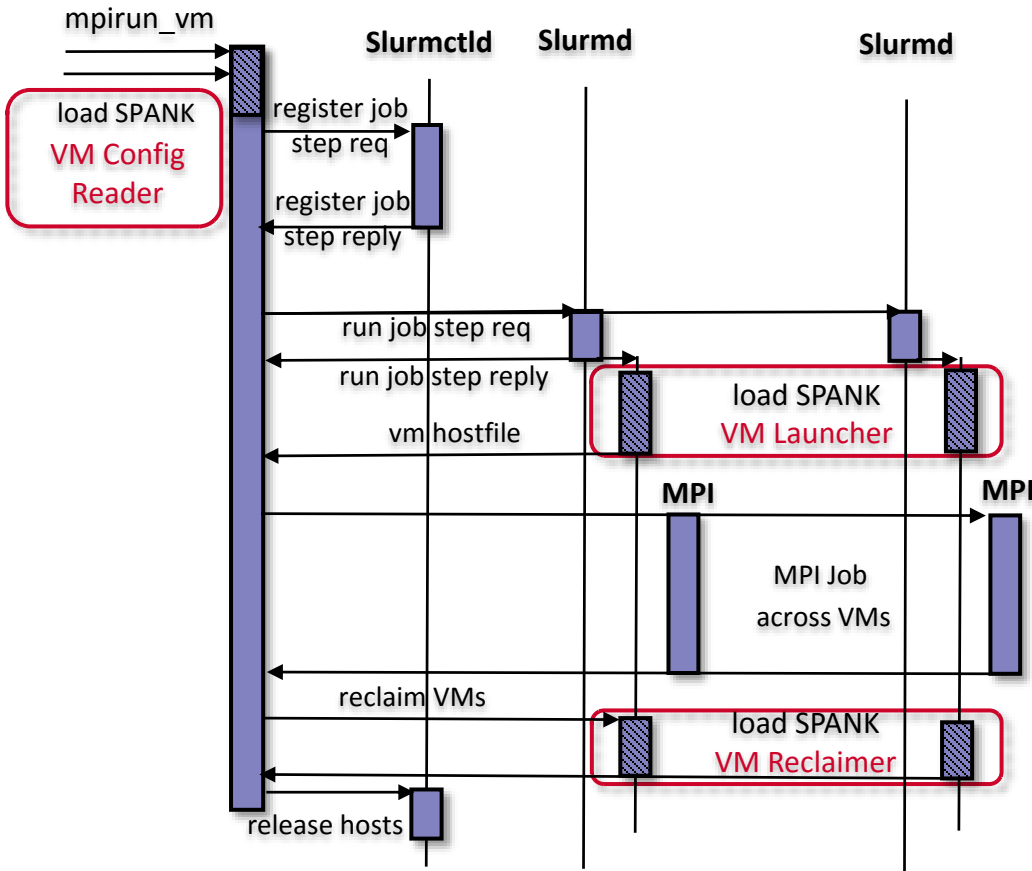

- **VM Configuration Reader** – Register all VM configuration options, set in the job control environment so that they are visible to all allocated nodes.
- **VM Launcher** – Setup VMs on each allocated nodes.
  - **File based lock** to detect occupied VF and exclusively allocate free VF
  - **Assign a unique ID** to each IVSHMEM and dynamically attach to each VM
- **VM Reclaimer** – Tear down VMs and reclaim resources

# Benefits of Plugin-based Designs for SLURM

- Coordination
  - With global information, SLURM plugin can manage SR-IOV and IVSHMEM resources easily for concurrent jobs and multiple users
- Performance
  - Faster coordination, SR-IOV and IVSHMEM aware resource scheduling, etc.
- Scalability
  - Taking advantage of the scalable architecture of SLURM
- Fault Tolerance
- Permission
- Security

# SLURM SPANK Plugin with OpenStack based Design

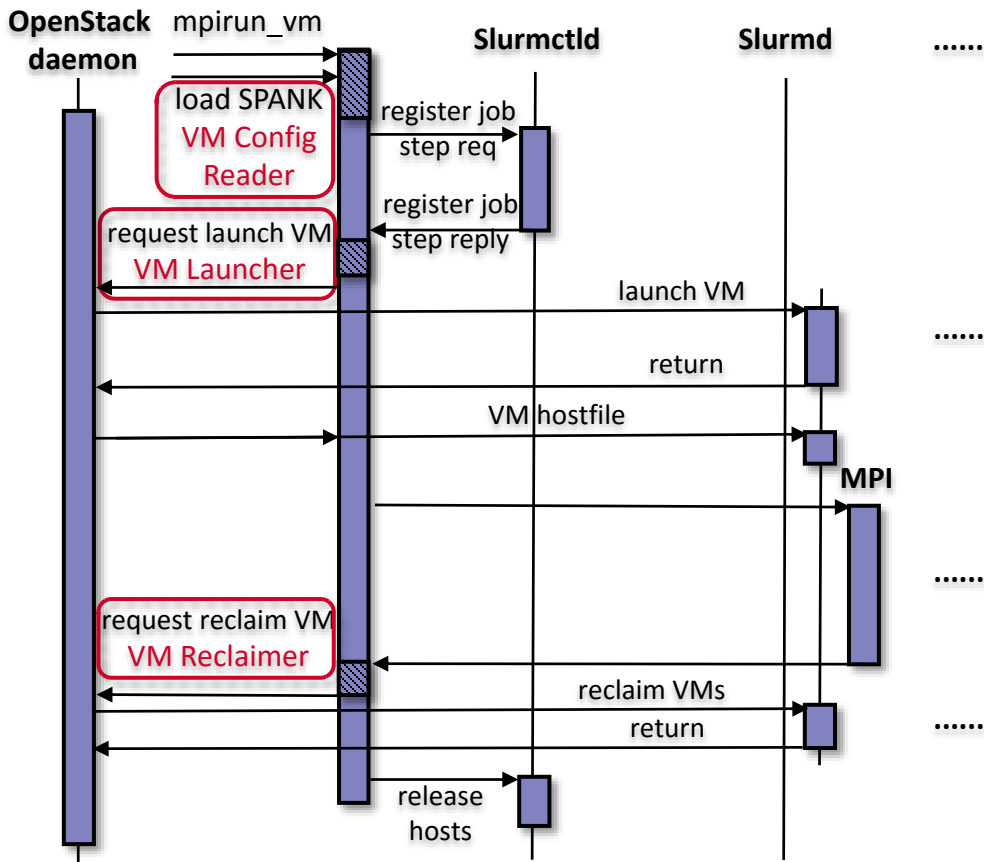

- **VM Configuration Reader** – VM options register
- **VM Launcher, VM Reclaimer** – Offload to underlying OpenStack infrastructure
  - **PCI Whitelist** to passthrough free VF to VM
  - **Extend Nova** to enable IVSHMEM when launching VM

J. Zhang, X. Lu, S. Chakraborty, D. K. Panda.  
SLURM-V: Extending SLURM for Building Efficient HPC Cloud with SR-IOV and IVShmem. Euro-Par, 2016

# Benefits of SLURM Plugin-based Designs with OpenStack

- Easy Management
  - Directly use underlying OpenStack infrastructure to manage authentication, image, networking, etc.
- Component Optimization
  - Directly inherit optimizations on different components of OpenStack
- Scalability
  - Taking advantage of the scalable architecture of both OpenStack and SLURM
- Performance

# Comparison on Total VM Startup Time

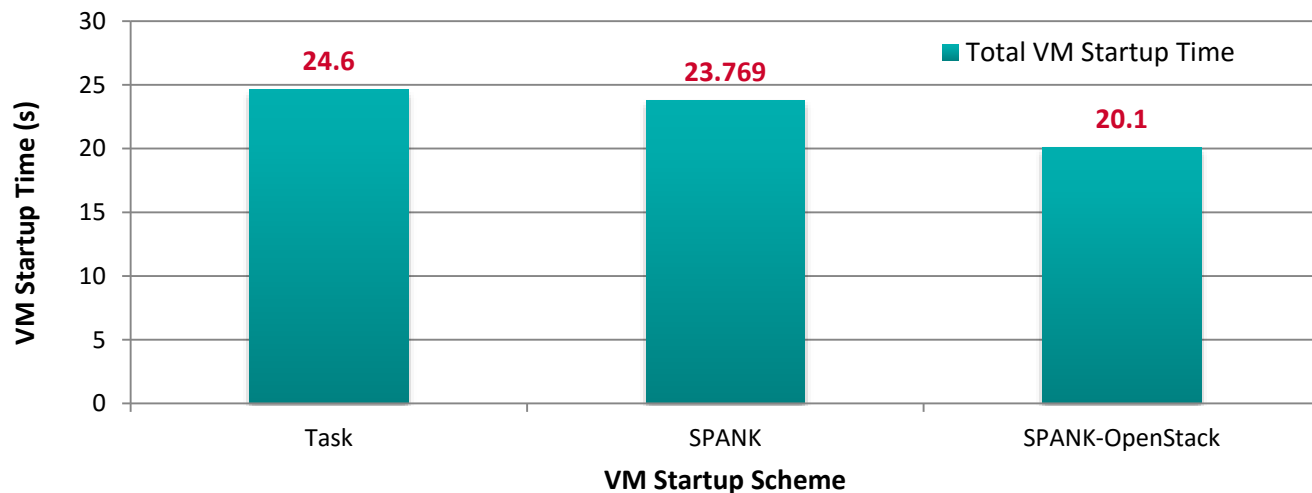

- Task - implement and explicitly insert three components in job batch file
- SPANK - SPANK Plugin based design
- SPANK-OpenStack – offload tasks to underlying OpenStack infrastructure



# Application-Level Performance on Chameleon (Graph500)

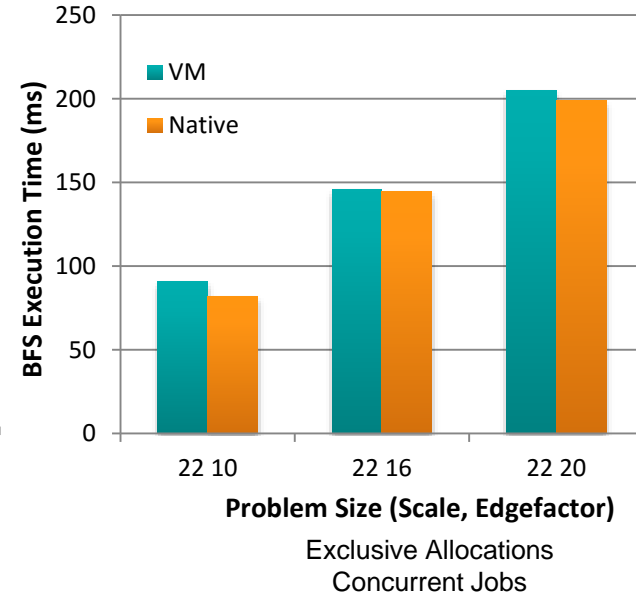
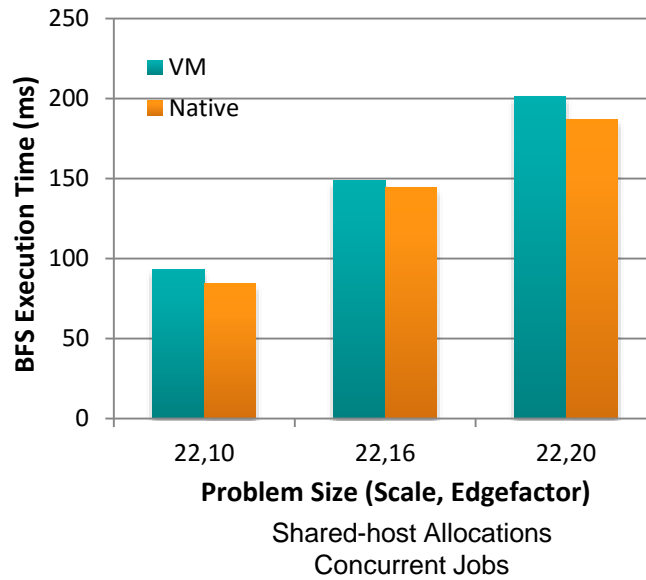
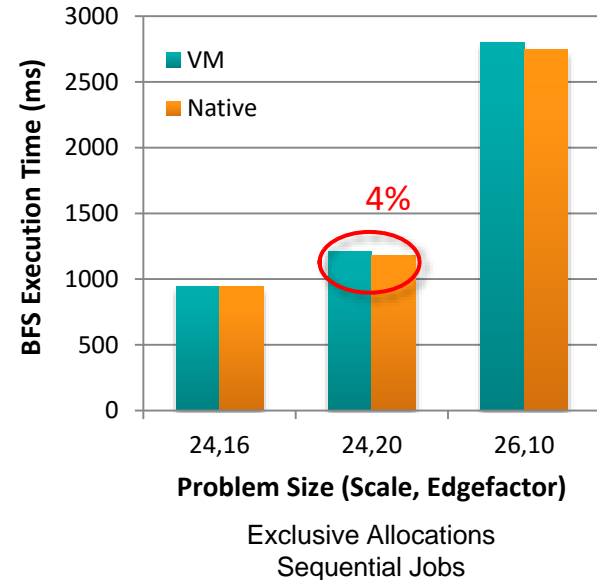

- 32 VMs across 8 nodes, 6 Core/VM
- EASJ - Compared to Native, less than 4% overhead with 128 Procs
- SACJ, EACJ – Also minor overhead, when running NAS as concurrent job with 64 Procs

# Approaches to Build HPC Clouds

- MVAPICH2-Virt with SR-IOV and IVSHMEM
  - Standalone, OpenStack
- MVAPICH2 with Containers
- MVAPICH2-Virt on SLURM
  - SLURM alone, SLURM + OpenStack
- **Big Data Libraries on Cloud**

# The High-Performance Big Data (HiBD) Project

- RDMA for Apache Spark
- RDMA for Apache Hadoop 2.x (RDMA-Hadoop-2.x)
  - Plugins for Apache, Hortonworks (HDP) and Cloudera (CDH) Hadoop distributions
- RDMA for Apache HBase
- RDMA for Memcached (RDMA-Memcached)
- RDMA for Apache Hadoop 1.x (RDMA-Hadoop)
- OSU HiBD-Benchmarks (OHB)
  - HDFS, Memcached, and HBase Micro-benchmarks
- <http://hibd.cse.ohio-state.edu>
- Users Base: 200 organizations from 27 countries
- More than 18,900 downloads from the project site
- RDMA for Impala (upcoming)

Available for InfiniBand and RoCE

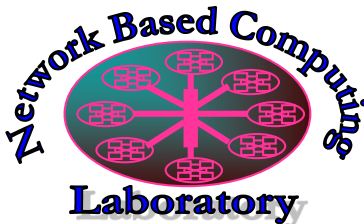

# Big Data on Cloud Computing Systems: Challenges Addressed by OSU So Far

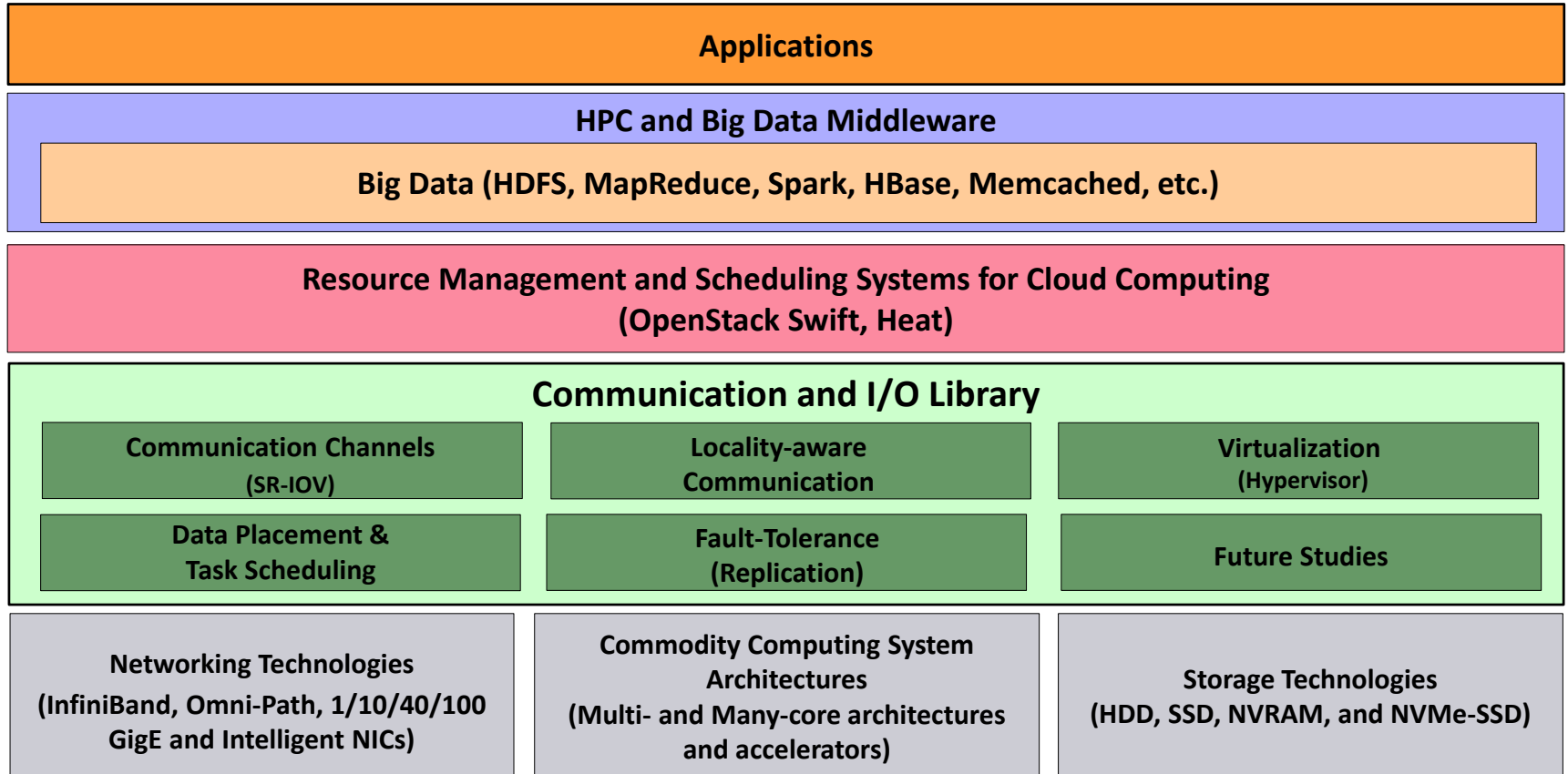

## High-Performance Apache Hadoop over Clouds: Challenges

- How about performance characteristics of native IB-based designs for Apache Hadoop over SR-IOV enabled cloud environment?
- To achieve locality-aware communication, how can the cluster topology be automatically detected in a scalable and efficient manner and be exposed to the Hadoop framework?
- How can we design virtualization-aware policies in Hadoop for efficiently taking advantage of the detected topology?
- Can the proposed policies improve the performance and fault tolerance of Hadoop on virtualized platforms?

*“How can we design a high-performance Hadoop library for Cloud-based systems?”*

# Impact of HPC Cloud Networking Technologies

- Network architectures
  - IB QDR, FDR, EDR
  - 40GigE
  - 40G-RoCE
- Network protocols
  - TCP/IP, IPoIB
  - RC, UD, Others
- Cloud Technologies
  - Bare-metal, SR-IOV

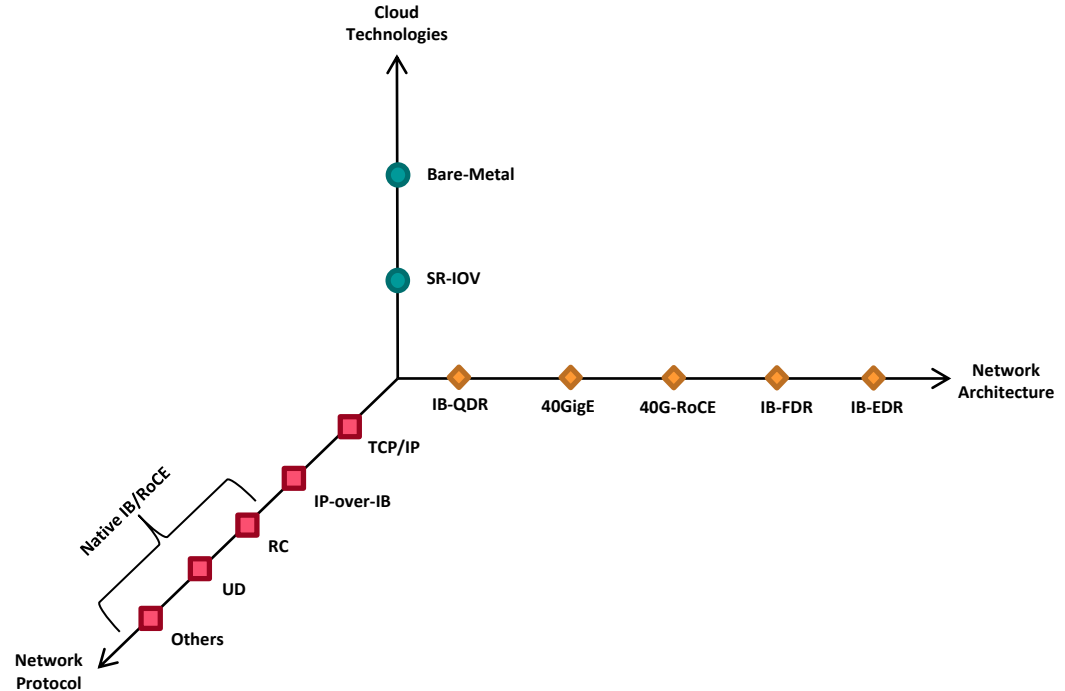

*Can existing designs of Hadoop components over InfiniBand need to be made “aware” of the underlying architectural trends and take advantage of the support for modern transport protocols that InfiniBand and RoCE provide?*

# Overview of IB-based Hadoop-RPC and HBase Architecture

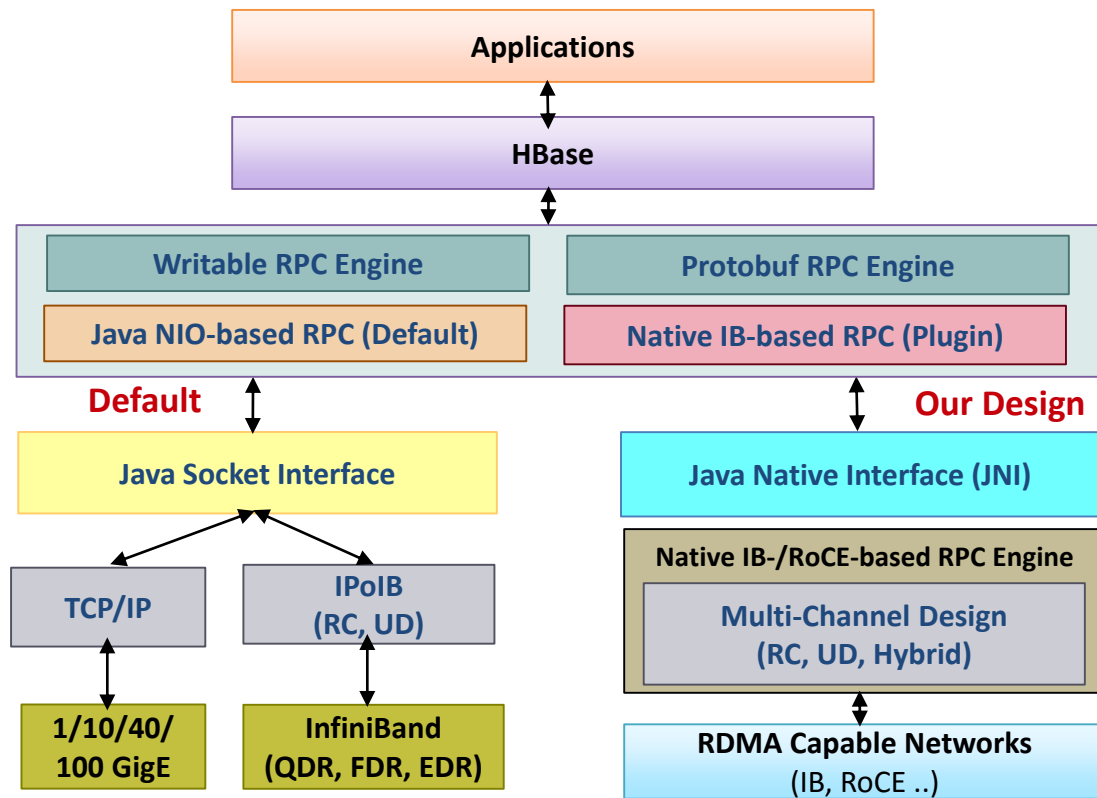

- **Design Features**

- SEDA-based Thread Management
- Support RC, UD, and Hybrid transport protocols
- Architecture-aware designs for Eager, packetized, and zero-copy transfers
- JVM-bypassed buffer management
- Intelligent buffer allocation and adjustment for serialization
- InfiniBand/RoCE support for bare-metal and SR-IOV

X. Lu, D. Shankar, S. Gugnani, H. Subramoni, and D. K. Panda, *Impact of HPC Cloud Networking Technologies on Accelerating Hadoop RPC and HBase*, CloudCom, 2016. (To be presented Session 6A: Architecture and Virtualization V, Thursday 11:00am)

# Performance Benefits for Hadoop RPC and HBase

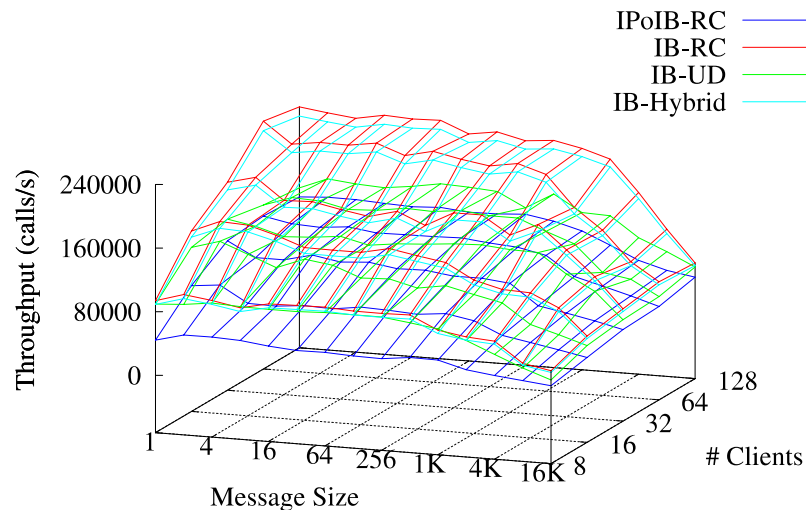

Hadoop RPC Throughput on Chameleon-Cloud

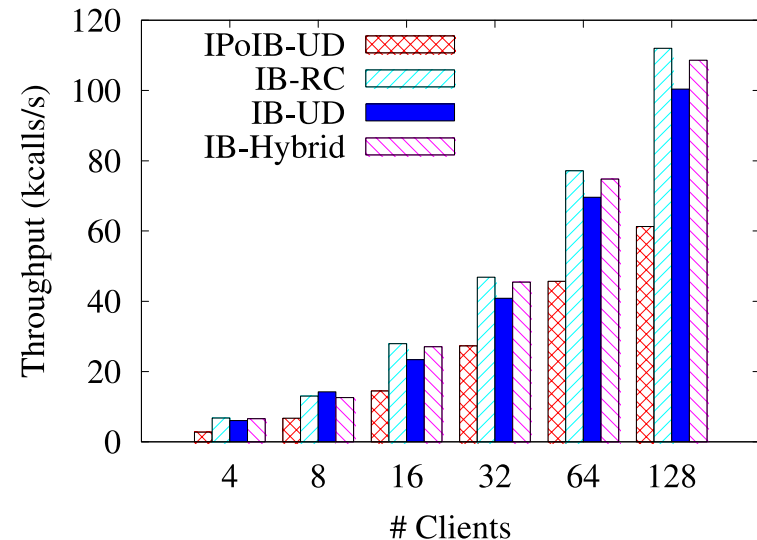

HBase YCSB Workload A on SDSC-Comet

- Hadoop RPC Throughput on Chameleon-Cloud-FDR
  - up to 2.6x performance speedup over IPoIB for throughput
- HBase YCSB Workload A (read: write=50:50) on SDSC-Comet-FDR
  - Native designs (RC/UD/Hybrid) always perform better than the IPoIB-UD transport
  - up to 2.4x performance speedup over IPoIB for throughput



# Overview of RDMA-Hadoop-Virt Architecture

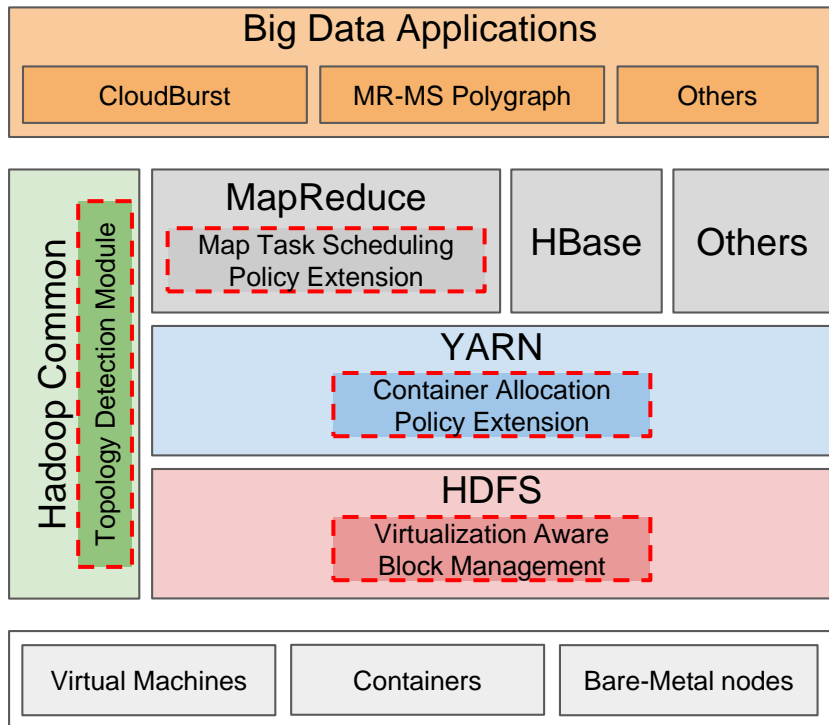

- Virtualization-aware modules in all the four main Hadoop components:
  - **HDFS**: Virtualization-aware Block Management to improve fault-tolerance
  - **YARN**: Extensions to Container Allocation Policy to reduce network traffic
  - **MapReduce**: Extensions to Map Task Scheduling Policy to reduce network traffic
  - **Hadoop Common**: Topology Detection Module for automatic topology detection
- Communications in HDFS, MapReduce, and RPC go through RDMA-based designs over SR-IOV enabled InfiniBand

S. Gugnani, X. Lu, D. K. Panda. Designing Virtualization-aware and Automatic Topology Detection Schemes for Accelerating Hadoop on SR-IOV-enabled Clouds. CloudCom, 2016. (To be presented in Session 3C: Big Data, Tuesday, 16:25)

# Evaluation with Applications

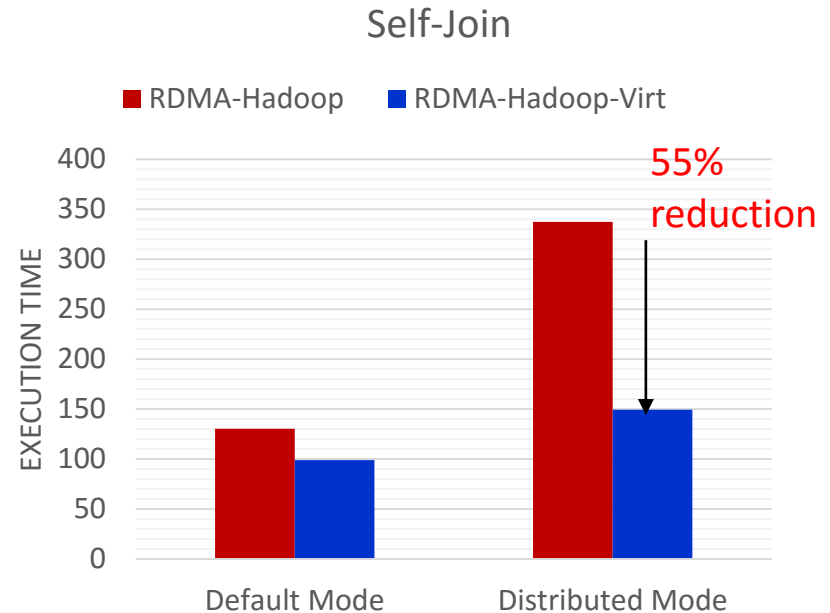
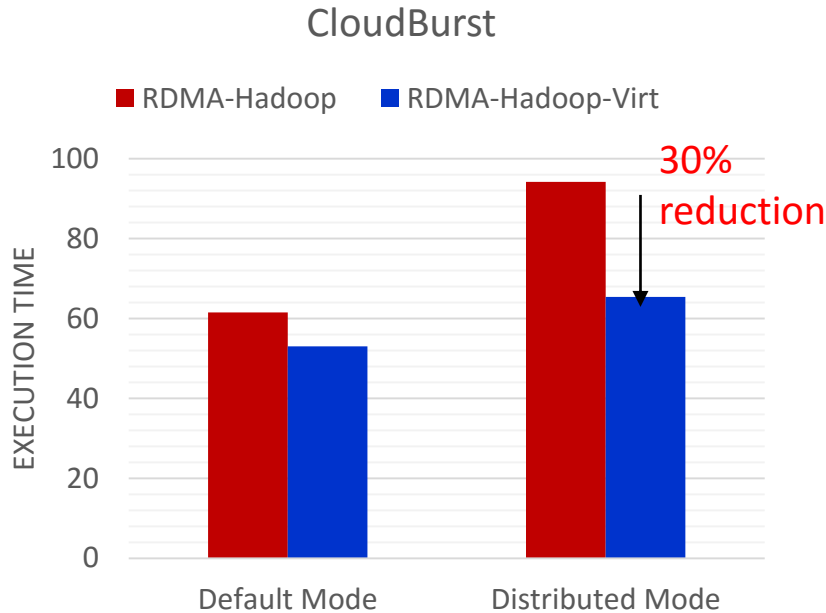

- 14% and 24% improvement with Default Mode for CloudBurst and Self-Join
- 30% and 55% improvement with Distributed Mode for CloudBurst and Self-Join

# Available Appliances on Chameleon Cloud\*

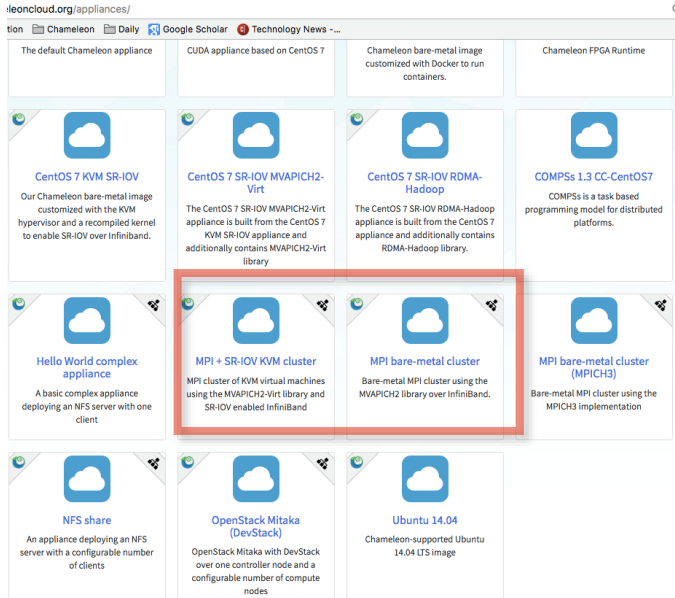

Appliance	Description
CentOS 7 KVM SR-IOV	Chameleon bare-metal image customized with the KVM hypervisor and a recompiled kernel to enable SR-IOV over InfiniBand. <a href="https://www.chameleoncloud.org/appliances/3/">https://www.chameleoncloud.org/appliances/3/</a>
MPI bare-metal cluster complex appliance (Based on Heat)	This appliance deploys an MPI cluster composed of bare metal instances using the MVAPICH2 library over InfiniBand. <a href="https://www.chameleoncloud.org/appliances/29/">https://www.chameleoncloud.org/appliances/29/</a>
MPI + SR-IOV KVM cluster (Based on Heat)	This appliance deploys an MPI cluster of KVM virtual machines using the MVAPICH2-Virt implementation and configured with SR-IOV for high-performance communication over InfiniBand. <a href="https://www.chameleoncloud.org/appliances/28/">https://www.chameleoncloud.org/appliances/28/</a>
CentOS 7 SR-IOV RDMA-Hadoop	The CentOS 7 SR-IOV RDMA-Hadoop appliance is built from the CentOS 7 appliance and additionally contains RDMA-Hadoop library with SR-IOV. <a href="https://www.chameleoncloud.org/appliances/17/">https://www.chameleoncloud.org/appliances/17/</a>

- Through these available appliances, users and researchers can easily deploy HPC clouds to perform experiments and run jobs with
  - High-Performance SR-IOV + InfiniBand
  - High-Performance MVAPICH2 Library over bare-metal InfiniBand clusters
  - High-Performance MVAPICH2 Library with Virtualization Support over SR-IOV enabled KVM clusters
  - High-Performance Hadoop with RDMA-based Enhancements Support

[\*] Only include appliances contributed by OSU NowLab

# MPI Complex Appliances based on MVAPICH2 on Chameleon

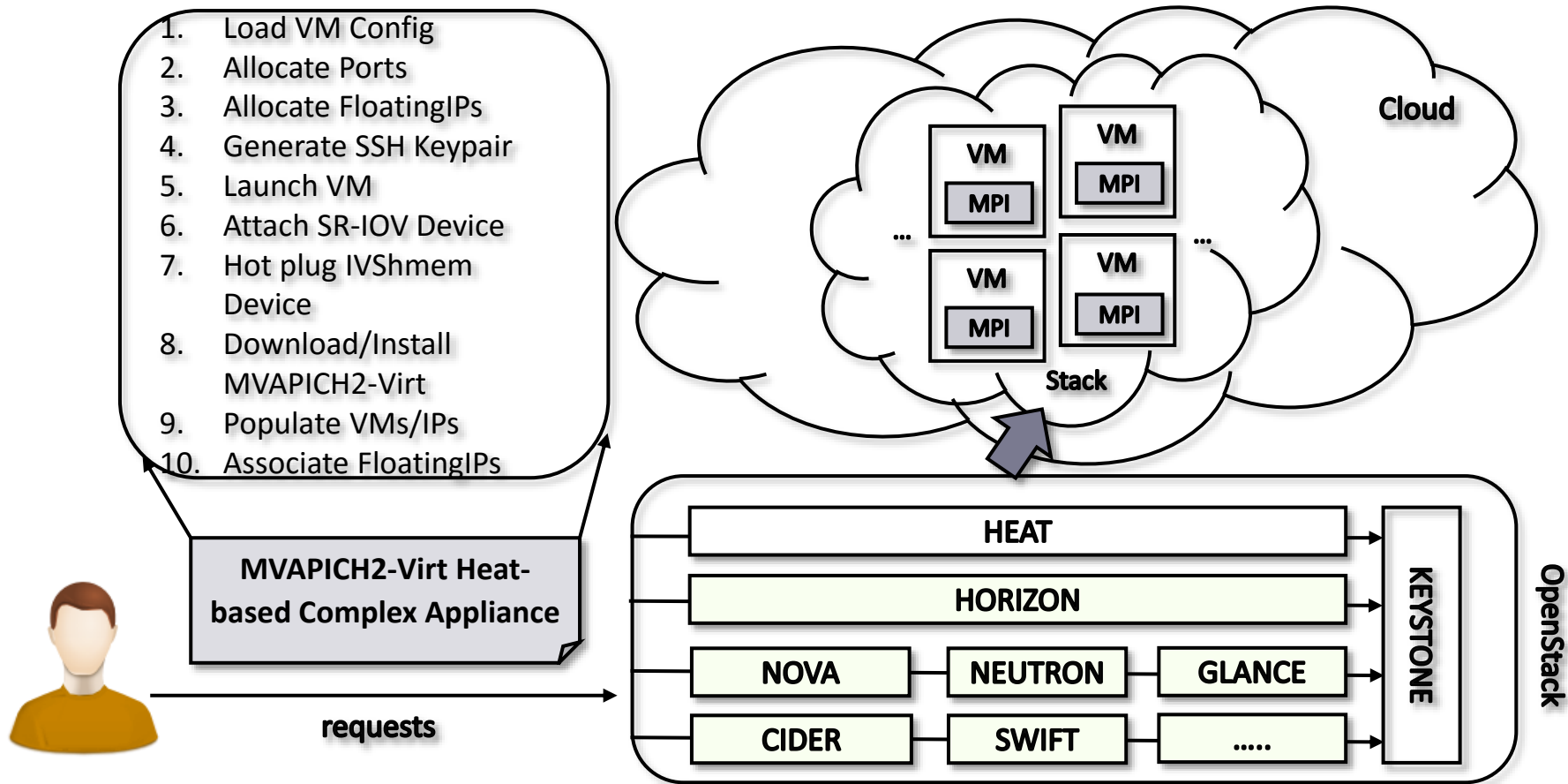

# Conclusions

- Outlined challenges and opportunities in running MPI and BigData applications in Cloud with performance
- MVAPICH2-Virt with SR-IOV and IVSHMEM is an efficient approach to build HPC Clouds
  - Standalone
  - OpenStack
- Building HPC Clouds with MVAPICH2-Virt on SLURM is possible
  - SLURM alone
  - SLURM + OpenStack
- Containers-based design for MPAPICH2-Virt
- Very little overhead with virtualization, near native performance at application level
- **MVAPICH2-Virt 2.1** is available for building HPC Clouds
  - SR-IOV, IVSHMEM, Docker support, OpenStack
- Appliances for MVAPICH2-Virt and RDMA-Hadoop are available for building HPC Clouds
- Future releases for supporting running MPI jobs in VMs/Containers with SLURM, VM migration, etc.
- SR-IOV/container support and appliances for other MVAPICH2 libraries (MVAPICH2-X, MVAPICH2-GDR, ...) and RDMA-Spark/Memcached

# Funding Acknowledgments

## Funding Support by



## Equipment Support by



# Personnel Acknowledgments

## **Current Students**

- A. Awan (Ph.D.)
- M. Bayatpour (Ph.D.)
- S. Chakraborty (Ph.D.)
- C.-H. Chu (Ph.D.)
- S. Guganani (Ph.D.)
- J. Hashmi (Ph.D.)
- N. Islam (Ph.D.)
- M. Li (Ph.D.)
- M. Rahman (Ph.D.)
- D. Shankar (Ph.D.)
- A. Venkatesh (Ph.D.)
- J. Zhang (Ph.D.)

## **Current Research Scientists**

- K. Hamidouche
- X. Lu
- H. Subramoni

## **Current Research Specialist**

- J. Smith

## **Past Students**

- A. Augustine (M.S.)
- P. Balaji (Ph.D.)
- S. Bhagvat (M.S.)
- A. Bhat (M.S.)
- D. Buntinas (Ph.D.)
- L. Chai (Ph.D.)
- B. Chandrasekharan (M.S.)
- N. Dandapanthula (M.S.)
- V. Dhanraj (M.S.)
- T. Gangadharappa (M.S.)
- K. Gopalakrishnan (M.S.)
- W. Huang (Ph.D.)
- W. Jiang (M.S.)
- J. Jose (Ph.D.)
- S. Kini (M.S.)
- M. Koop (Ph.D.)
- K. Kulkarni (M.S.)
- R. Kumar (M.S.)
- S. Krishnamoorthy (M.S.)
- K. Kandalla (Ph.D.)
- P. Lai (M.S.)
- J. Liu (Ph.D.)
- M. Luo (Ph.D.)
- A. Mamidala (Ph.D.)
- G. Marsh (M.S.)
- V. Meshram (M.S.)
- A. Moody (M.S.)
- S. Naravula (Ph.D.)
- R. Noronha (Ph.D.)
- X. Ouyang (Ph.D.)
- S. Pai (M.S.)
- S. Potluri (Ph.D.)
- R. Rajachandrasekar (Ph.D.)
- G. Santhanaraman (Ph.D.)
- A. Singh (Ph.D.)
- J. Sridhar (M.S.)
- S. Sur (Ph.D.)
- H. Subramoni (Ph.D.)
- K. Vaidyanathan (Ph.D.)
- A. Vishnu (Ph.D.)
- J. Wu (Ph.D.)
- W. Yu (Ph.D.)

## **Past Research Scientist**

- S. Sur

## **Past Programmers**

- D. Bureddy
- M. Arnold
- J. Perkins

## **Past Post-Docs**

- D. Banerjee
- X. Besseron
- H.-W. Jin
- J. Lin
- M. Luo
- E. Mancini
- S. Marcarelli
- J. Vienne
- H. Wang

# Thank You!

[panda@cse.ohio-state.edu](mailto:panda@cse.ohio-state.edu)

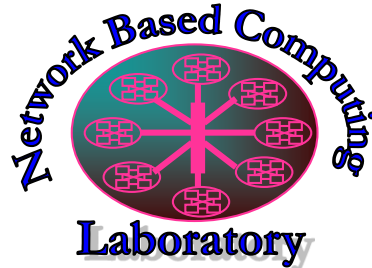

Network-Based Computing Laboratory

<http://nowlab.cse.ohio-state.edu/>



The MVAPICH2/MVAPICH2-X Project

<http://mvapich.cse.ohio-state.edu/>



High-Performance  
Big Data

The High-Performance Big Data Project

<http://hibd.cse.ohio-state.edu/>